

## 1. Overview

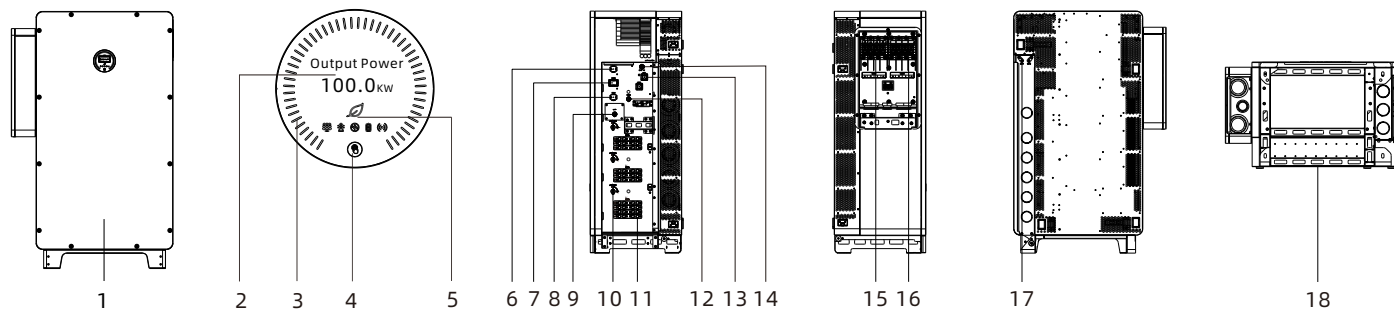

(1) Front panel	(2) OLED display screen	(3) Battery status indicator	(4) Push button
(5) System indicator	(6) BMS communication port	(7) Parallel communication port	(8) Monitor communication port
(9) Network communication port	(10) DC switch	(11) PV terminal	(12) DRMS communication port
(13) Battery terminal	(14) BMS power supply port	(15) GRID terminal	(16) LOAD terminal
(17) Communication port (WiFi&4G)	(18) Base		

**⚠ Note:**

- The content of this document is continually reviewed and amended, where necessary. WAET reserves the right to make changes to the material at any time and without notice. Unless otherwise agreed, this document is for quick installation guidance only. All information and suggestions in this document do not constitute a warranty of any kind, express or implied. WAET reserves all rights for final explanation.
- This document is for quick installation guidance only. For details, please refer to the User Manual.
- Machine damage caused by failure to follow the instructions is not covered under any warranty.

## 2. Installation

### System overview

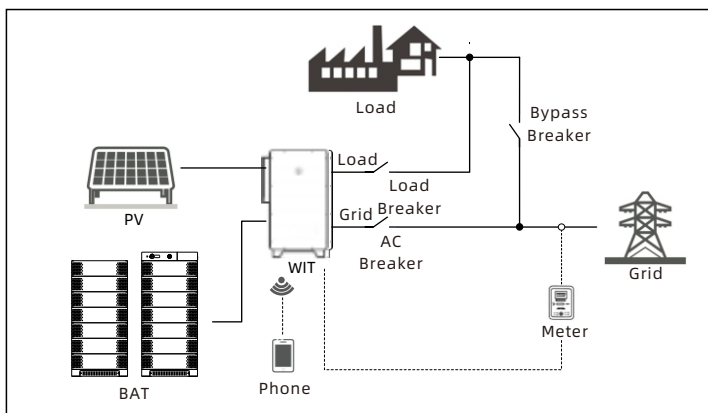

### 2.1 Installation requirements

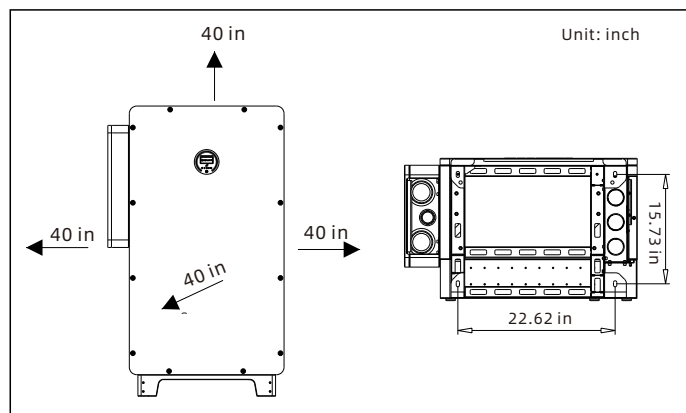

### 2.2 Floor-mounted installation

Unit: inch

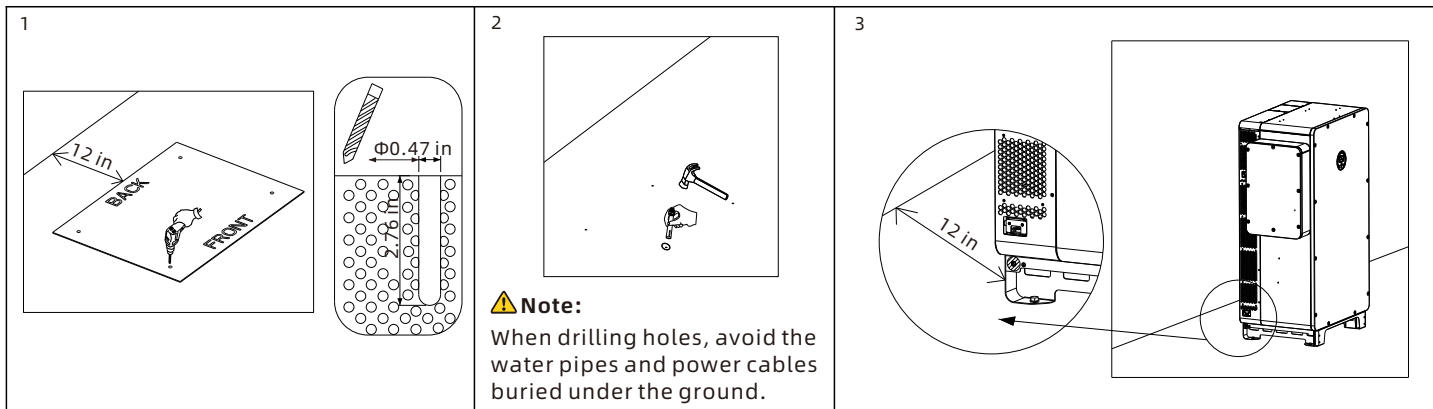

**⚠ Note:**

- The Load Breaker and the Bypass Breaker should be interlocked.
- When determining the installation position of the inverter, please consider the position of the batteries and the distribution panel.
- For export limitation, you are advised to connect an energy meter and current transformers to the inverter.

### 3. Connecting cables

Please prepare the cables listed below before electrical connections.

No.	Cable	Type	Recommended specifications
1	Grounding cable	A multiple-core copper cable (yellow and green)	1AWG
2	Grid cable	A multi-core copper cable	1/0AWG-400kcmil
3	Load cable	A multi-core copper cable	4AWG-400kcmil
4	PV input cable	Photovoltaic cable	12AWG-10AWG
5	Battery power supply cable	A single-core copper cable (red and black)	1AWG
6	BMS power supply cable	A multi-core copper cable	20 AWG-14AWG
7	Other communication cable	Shielded twisted pair	26AWG-20AWG

**⚠ Note:**

1. Make sure all switches are OFF before connecting the cables. For personal safety, do not operate when power-on.
2. If the diameter of the cable does not match the terminal, please contact our after-sales personnel.
3. The current carrying capacity of cables should comply with locally applicable regulations.
4. The cables used shall have a rating of not less than 90 °C.

#### 3.1 Grounding

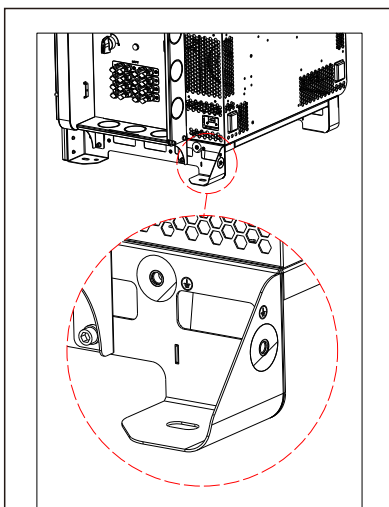

**⚠ Note:**

Ensure that the ground point on the enclosure base has been reliably connected to the on-site ground busbar.

#### 3.2 GRID and LOAD side cable connection

1

2

3

4

5

**⚠ Note:** Once the cable connections are complete, check if the cable feed-through pipes and cables are secured in place, and finally lock the AC junction box cover.

#### 3.3 PV connection

##### 3.3.1 Assembling the PV connectors

1

Unit: inch

2

Ensure that the cable cannot be pulled out from the terminal after crimping.

3

Positive metal connector

Negative metal connector

Pull the PV cables back to check that they are connected securely.

4

Ensure secure connection by tightening the locking nut.

5

Make sure the cable polarity is correct.

### 3.3.2 Connecting the PV input cables

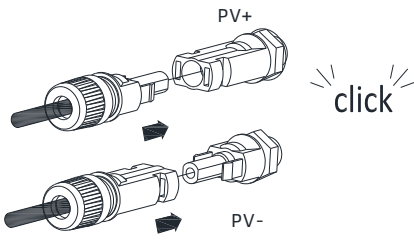
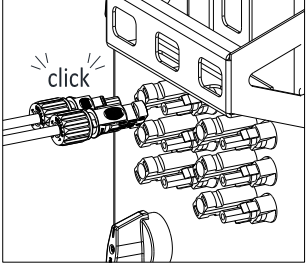
<p>1</p> 	<p>2</p> 	<p><b>⚠ Note:</b></p> <ol style="list-style-type: none"> <li>1. Before installing the PV terminals, please confirm that the PV input voltage and current do not exceed the MPPT limits.</li> <li>2. When installing the PV terminals, identify the positive and negative terminals and connect them to the inverter respectively following the color convention.</li> <li>3. A "click" sound will be heard when the terminal is connected. Please gently pull the PV cable back to make sure it is securely connected.</li> </ol>
--------------------------------------------------------------------------------------------	--------------------------------------------------------------------------------------------	-----------------------------------------------------------------------------------------------------------------------------------------------------------------------------------------------------------------------------------------------------------------------------------------------------------------------------------------------------------------------------------------------------------------------------------------------------------------------------------------------------------------------------------

### 3.4 Connection on the battery side

#### 3.4.1 Connecting the battery power cable

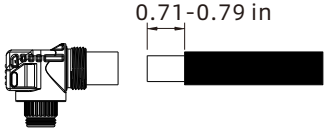
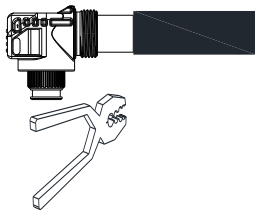
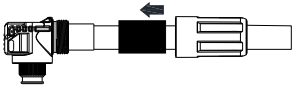
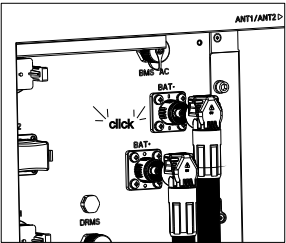
<p>1</p> 	<p>2</p> 	<p>3</p> 	<p>4</p> 
--------------------------------------------------------------------------------------------	--------------------------------------------------------------------------------------------	---------------------------------------------------------------------------------------------	----------------------------------------------------------------------------------------------

**⚠ Note:**

1. Before installing the battery terminals, please ensure that the battery input voltage and current are within the acceptable range.
2. When installing battery terminals, identify the positive and negative terminals and connect them to the inverter according to the color convention.
3. When connecting the terminals, ensure that you hear a "click" sound. Please gently pull back the battery cables to ensure a secure connection.

#### 3.4.2 Connecting the BMS power supply cable

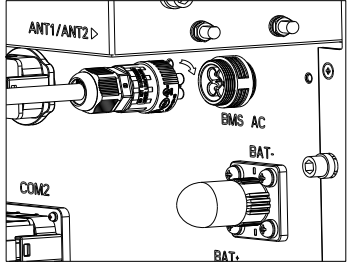
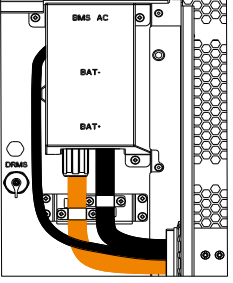
		<table border="1" data-bbox="868 1272 1474 1460"> <thead> <tr> <th colspan="2">BMS power supply port description</th> </tr> <tr> <th>Label</th> <th>Definition</th> </tr> </thead> <tbody> <tr> <td>L</td> <td>L1</td> </tr> <tr> <td>N</td> <td>L2</td> </tr> <tr> <td>PE</td> <td>PE</td> </tr> </tbody> </table> <p><b>⚠ Note:</b></p> <ol style="list-style-type: none"> <li>1. Thread the BMS power supply cable and batter power cables through the first cable routing hole of the inverter and connect them to the corresponding terminals.</li> <li>2. Ensure that all cables are securely connected, then lock the junction box cover on the battery side.</li> </ol>	BMS power supply port description		Label	Definition	L	L1	N	L2	PE	PE
BMS power supply port description												
Label	Definition											
L	L1											
N	L2											
PE	PE											

### 3.5 Communication cable installation

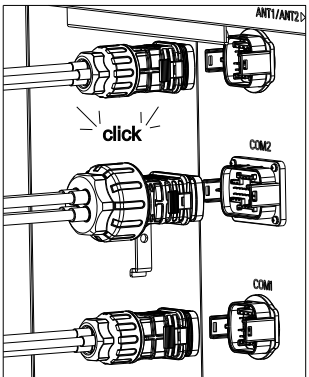
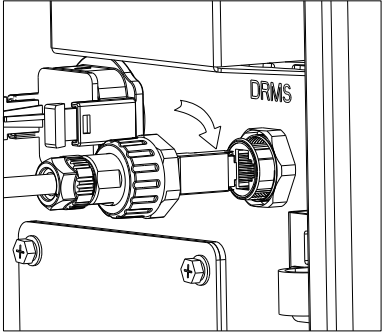
	<p>DRMS communication port</p> 	<p>Follow the installation steps:</p> <ol style="list-style-type: none"> <li>1. Remove the waterproof cover from the network communication port.</li> <li>2. Insert a network cable into the port and tighten the protective cover.</li> <li>3. Ensure that the connection is correct and secured, the sealing rubber ring is properly seated into the gland.</li> </ol>
-------------------------------------------------------------------------------------	---------------------------------------------------------------------------------------------------------------------	--------------------------------------------------------------------------------------------------------------------------------------------------------------------------------------------------------------------------------------------------------------------------------------------------------------------------------------------------------------------------

### Monitor communication port

Monitor communication port description (COM1)					
No.	Description	Note	No.	Description	Note
1	RS485A4	RS485_4	9	RS485B2 (OUT)	RS485 output port for the meter
2	RS485B4		10	Res_RS4851B	RS485 matching resistor
3	RS485A1(IN)	RS485 terminal for external communication	11	PE	Grounding
4	RS485B1(IN)		12	REPO1	The WIT Inverter shutdown input dry contact signal
5	Res_RS4851A	RS485 matching resistor	13	REPO2	
6	RS485A2 (IN)	RS485 input port for the meter	14	DO1	Generator start-up output dry contact signal
7	RS485B2 (IN)		15	DO2	
8	RS485A2 (OUT)	RS485 output port for the meter	16	PE	Grounding

### Parallel communication port

Parallel communication port description(COM2)					
No.	Description	Note	No.	Description	Note
1	24V.S	Output 24V signal	16	CAN2_H (OUT)	Parallel communication CAN2 signal (output)
2	GND.S		17	CAN2_L (OUT)	
3	CAN1_H (IN)	Parallel communication CAN1 signal (input)	18	RS485_1A (OUT)	Parallel communication 485 signal (output)
4	CAN1_L (IN)		19	RS485_1B (OUT)	
5	GND.S		20	PE	Grounding
6	CAN2_H (IN)	Parallel communication CAN2 signal (input)	21	RS485_5A (IN)	Low frequency synchronization 485 signal(input)
7	CAN2_L (IN)		22	RS485_5B (IN)	
8	RS485_1A (IN)	Parallel communication 485 signal (input)	23	RS485_5A (OUT)	Low frequency synchronization 485 signal(output)
9	RS485_1B (IN)		24	RS485_5B (OUT)	
10	PE	Grounding	25	RS485_4A (IN)	Parallel RS485_4 communication (input)
11	24V.S	Output 24V signal	26	RS485_4B (IN)	
12	GND.S		27	RS485_4A (OUT)	Parallel RS485_4 communication (output)
13	CAN1_H (OUT)	Parallel communication CAN1 signal (output)	28	RS485_4B (OUT)	
14	CAN1_L (OUT)		29	CAN3_H	Parallel communication CAN signal
15	GND.S		30	CAN3_L	

### BMS communication port

BMS Communication port description(BMS-COM)					
No.	Description	Note	No.	Description	Note
1	Wakeup+	Battery wake up signal	6	CANL	The PCS communicates with the battery via CAN
2	Wakeup-		7	CAN.GND	
3	RS485A3	The PCS communicates with the battery via RS485	8	DI1	Battery shutdown input signal dry contact signal
4	RS485B3		9	DI1	
5	CANH	The PCS communicates with the battery via CAN	16	PE	Grounding

### 3.5.1 Installing the antenna

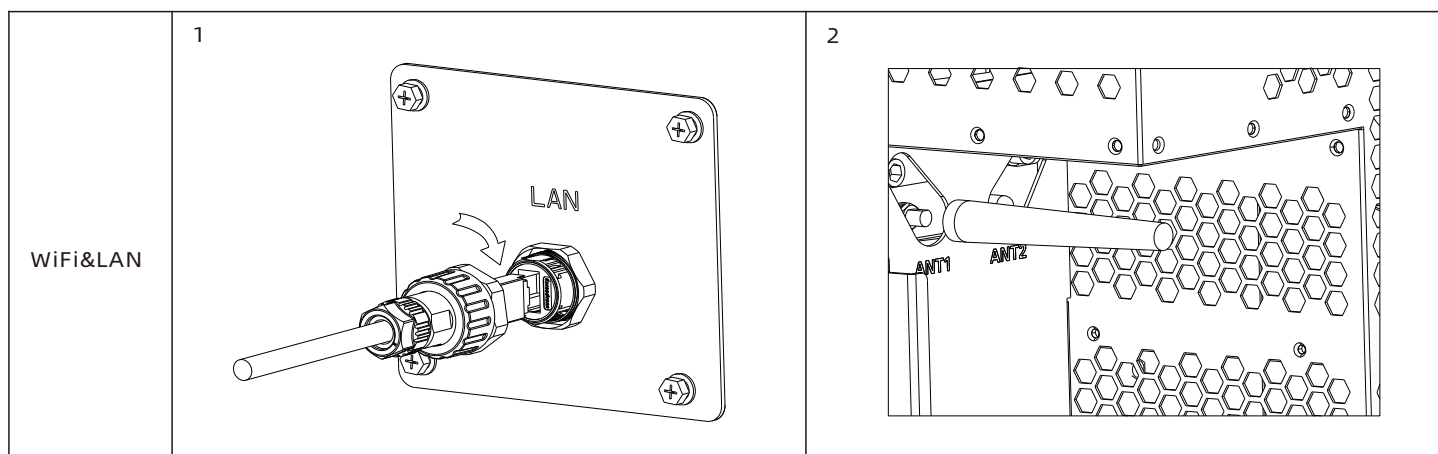

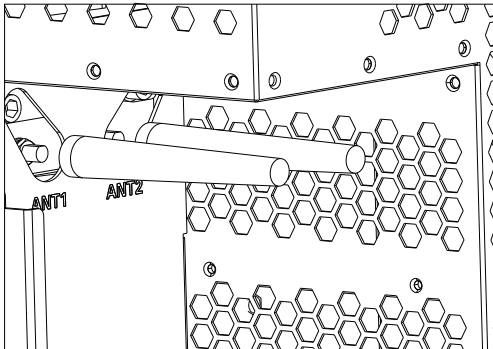
<p>WiFi&amp;4G</p>		<p>Please follow the steps below:</p> <ol style="list-style-type: none"> <li>1. Remove the antenna dust cap or the protective cover from the network port.</li> <li>2. Install the antenna as shown in the diagram.</li> <li>3. Connect the antenna to the inverter correctly and tighten it.</li> <li>4. The inverter can establish communication via WiFi&amp;LAN (Standard) or WiFi&amp;4G.</li> </ol>
--------------------	-----------------------------------------------------------------------------------	-----------------------------------------------------------------------------------------------------------------------------------------------------------------------------------------------------------------------------------------------------------------------------------------------------------------------------------------------------------------------------------------------------------

### 3.6 Wiring diagram

#### 3.6.1 Wiring on the right of the inverter

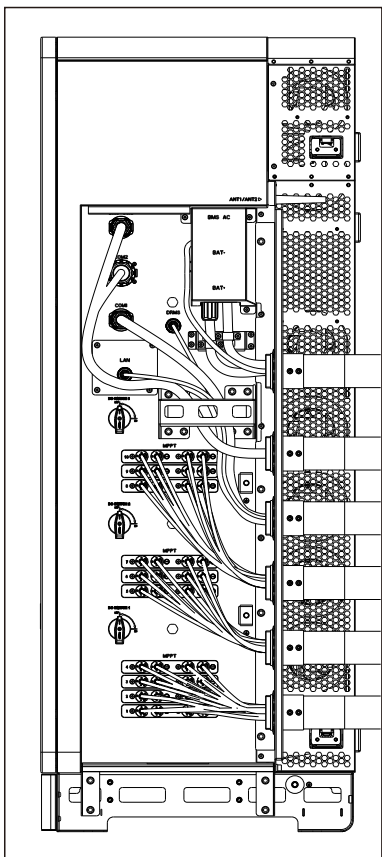

#### 3.6.2 Positions of the inverter and the battery system

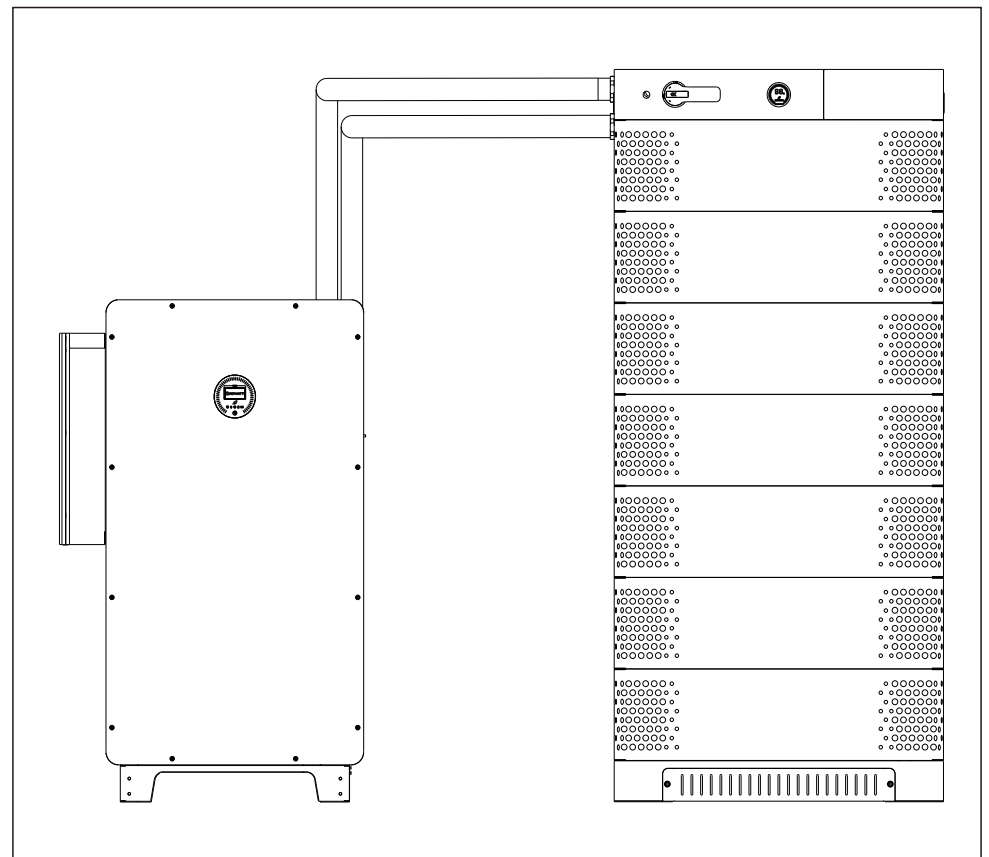

### 3.7 Right side cover plate mounting

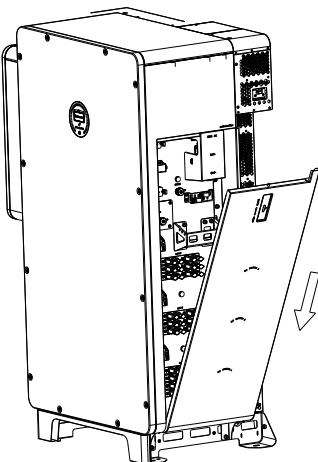
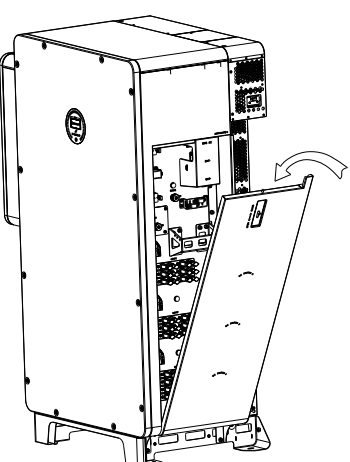
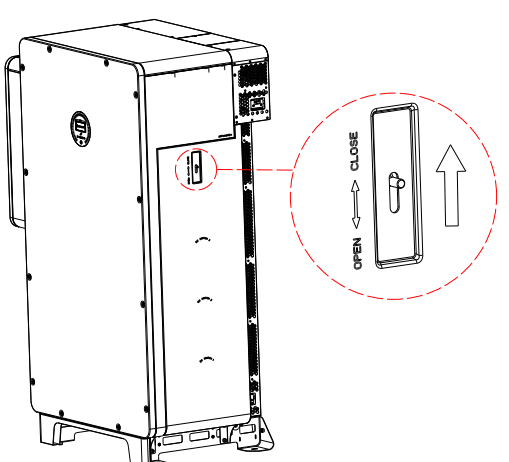
<p>1</p> 	<p>2</p> 	<p>3</p> 
----------------------------------------------------------------------------------------------	----------------------------------------------------------------------------------------------	-----------------------------------------------------------------------------------------------

## 4. Post-installation check

Number	Checking item	Number	Checking item
1	The hybrid inverter is installed correctly and reliably.	2	Ground cables are connected securely.
3	All switches are in the OFF position.	4	All cables are connected correctly and securely.
5	The cover of the AC junction box is secured.	6	All the unused connectors are sealed.
7	The right panel is closed and secured.	8	Put away the unused accessories.
9	The installation position is clean and tidy.		

## 5. Powering on/off the inverter

### ⚠ Note:

Before power-on, please make sure all the voltage and current are within the specified range. Otherwise it will cause damage to the hybrid inverter.

Perform the following steps to power on the system:

1. Make sure that the Max. short-circuit current of the string does not exceed the PCS specification value, then turn on the DC switch.
2. Turn on the breaker between the grid and the inverter.
3. Turn on the breaker between the battery and the inverter, then turn on the switch on the battery.
4. The system will be powered on automatically when all the requirements are met.

To shut down the system, you need to send a shutdown command on the APP or website. Wait until the system is completely powered off, then turn off the switches in reverse order.

## 6. Description of the display panel

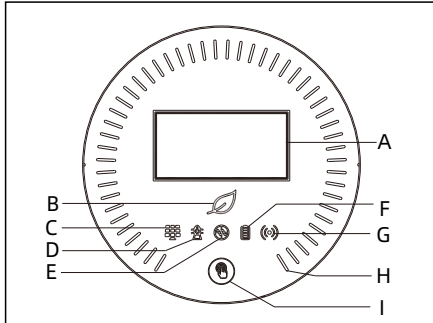

Indicator	Function	Indicator	Function
A	OLED display screen	F	Battery connection indicator
B	System indicator	G	Communication indicator
C	PV indicator	H	Battery status indicator
D	On-grid indicator	I	Push button
E	Off-grid indicator		

## 7. Service and contact

SHEN ZHEN WAET Technology Co., Ltd

101-102, Block A Fuyu Residence, Pankeng road (No. 108, Qinde Road), Second Industrial Zone, Baihua Community, Guangming street, Guangming District, Shenzhen, P.R. China.

T +86-13802559214

E waetpower@outlook.com

W www.waeta.cn



Download  
Manual