

## 1. Overview

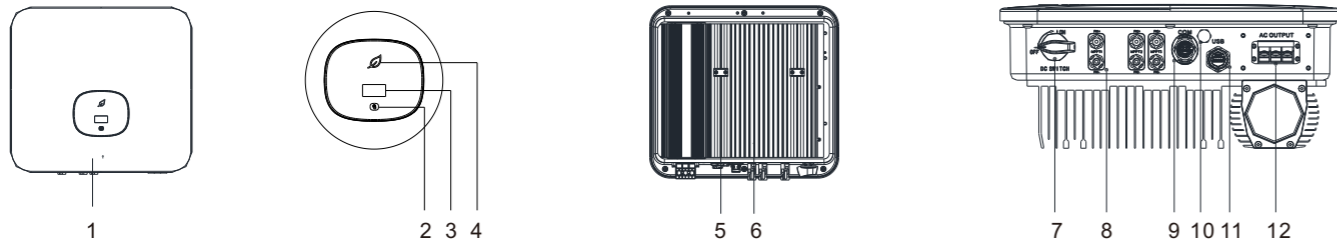

- |                |                 |                |                  |                     |
|----------------|-----------------|----------------|------------------|---------------------|
| (1)Front panel | (2)Touch button | (3)OLED screen | (4)LED indicator | (5)Mounting bracket |
| (6)Heat sink   | (7)DC switch    | (8)PV terminal | (9)COM port      | (10)Vent valve      |
| (11)USB port   | (12)AC terminal |                |                  |                     |

### ⚠ Note:

- This document is for quick installation guidance only, please refer to User Manual for more details.
- WAET shall not be liable for any damage resulting from unproper installation.

## 2. Installation

### System overview

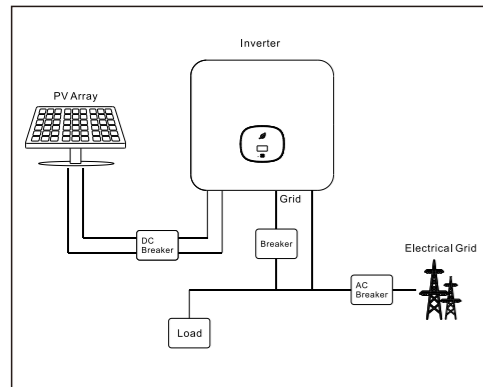

### 2.1 Installation requirements

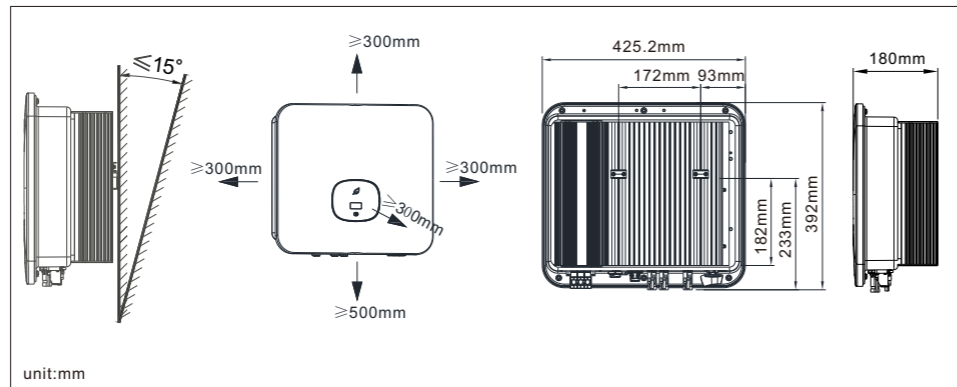

### 2.2 Wall mounting

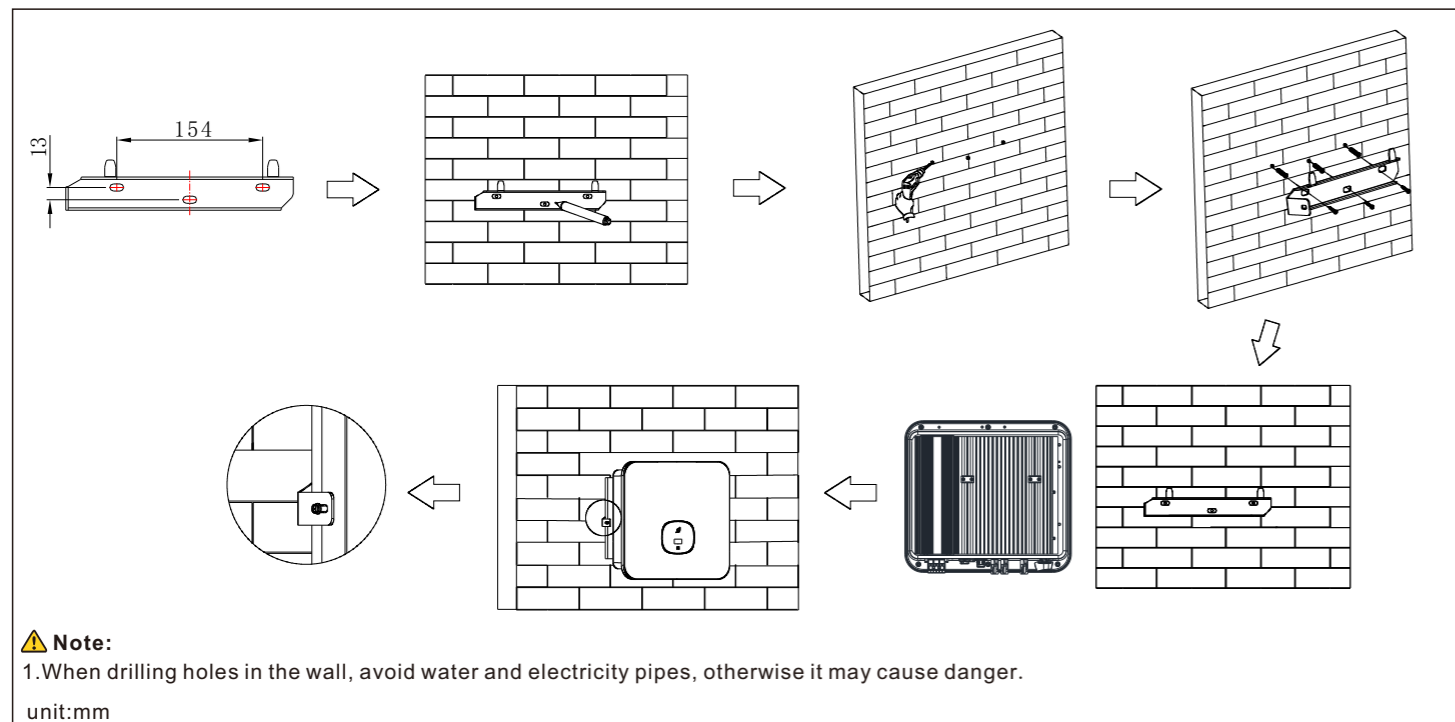

### ⚠ Note:

- When drilling holes in the wall, avoid water and electricity pipes, otherwise it may cause danger.

unit:mm

### 2.3 Communication module installation

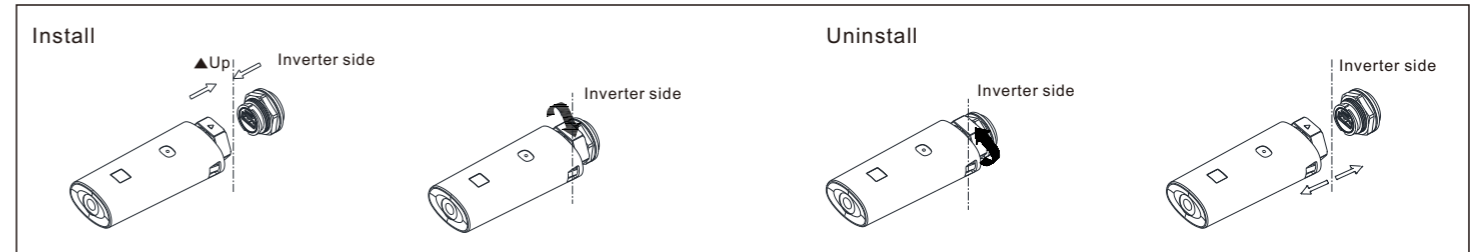

## 3. Electrical connection

Please prepare the cable before connecting as follows.

No.	Cable name	Type	Recommend model
1	Protective grounding wire	Single multi-core yellow-green wire	6mm <sup>2</sup>
2	AC output wire	Two or three polychromatic multi-core copper wires	6mm <sup>2</sup>
3	PV input wire	PV wire (such as PV1-F)	4mm <sup>2</sup> - 6mm <sup>2</sup>
4	Communication wire	RS485	/

### ⚠ Note:

- Please make sure all switches are in "OFF" position before wiring. For personal safety, please do not operate with electricity.
- If the diameter of the cable does not match the terminal, or the cable is aluminum wire, please contact our after-sales personnel.

### 3.1 Grounding

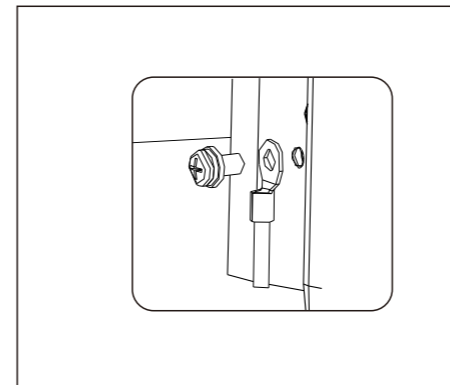

### 3.2 AC output connection

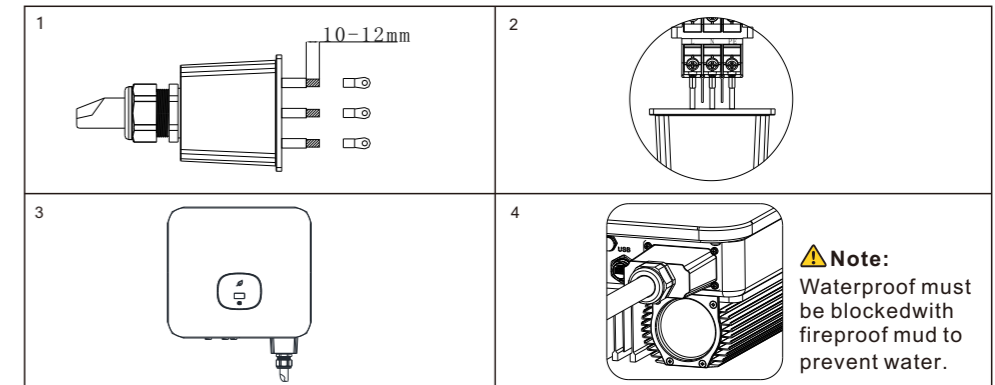

**⚠ Note:**  
Waterproof must be blocked with fireproof mud to prevent water.

### 3.3 DC connection

#### 3.3.1 PV input terminal installation

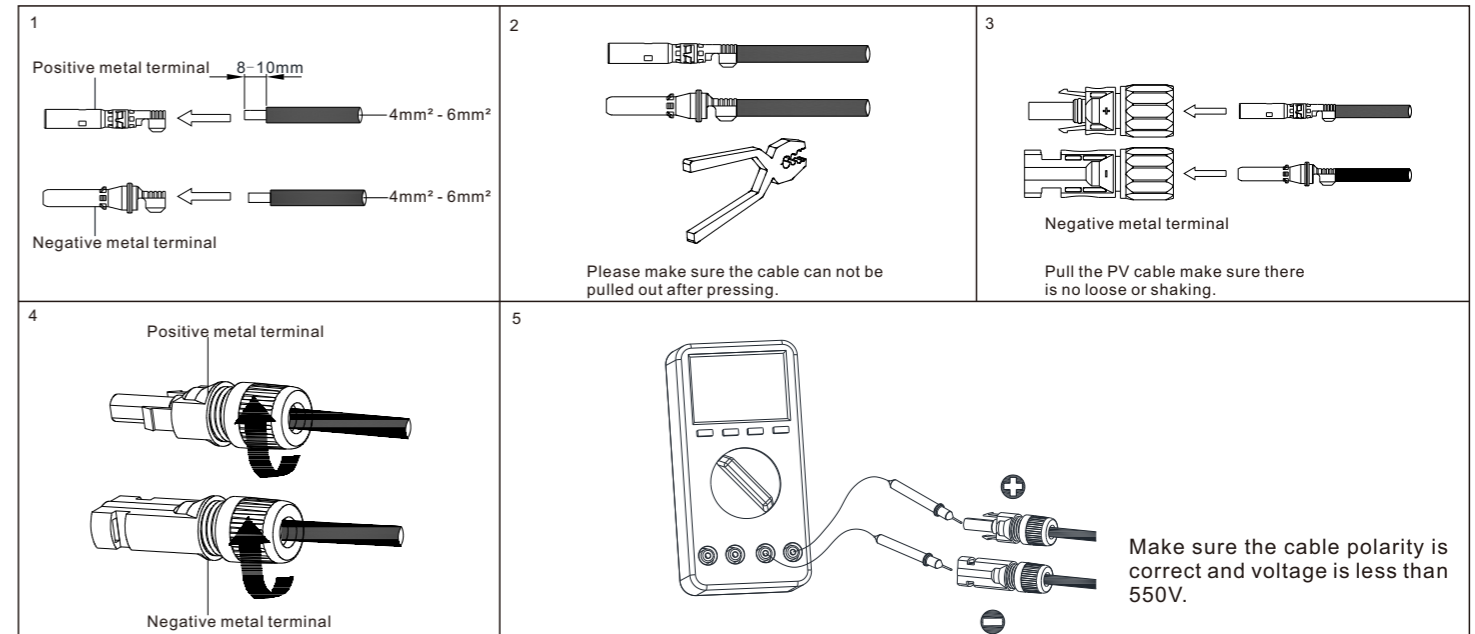

Make sure the cable polarity is correct and voltage is less than 550V.

### 3.3.2 Plug in PV terminal

**⚠ Note:**

- Before installing the PV terminal, please double-check that the PV input voltage and current do not exceed the MPPT limits.
- When installing the PV terminal, pay attention to the difference between the positive and negative poles and the one-to-one correspondence between the terminals and the machine.
- There is a "click" sound when the terminal is connected, please gently pulling the PV wire to make sure there is no loose or pulling off.

### 3.3.3 Communication cable installation

**COM Port Pin Definitions (Type 1)**

No.	Definition	No.	Definition
1	RS485A1	3	RS485A2
2	RS485B1	4	RS485B2

Signal for communication

Signal for Smart Meter

**COM Port Pin Definitions (Type 2&3)**

No.	Description	Remarks
1	+12V	Dry contact : external relay coil interface, power is not more than 2W
2	COM	
3	RS485A1	Rs485 communication port
4	RS485B1	
7	RS485B2	Meter communication port
8	RS485A2	
9	DRM1/5	/
10	DRM2/6	/
11	DRM3/7	/
12	DRM4/8	/
13	REF/GEN	GND
14	DRM0/COM	/
15	CT-P	White
16	CT-N	Black or Blue

**⚠ Note:**

There are three type signal connectors for different country.

## 4. Connecting Meter

The following table describes how we can connect EASTRON meter (SDM 120CT-M(40mA)) to inverter:

Meter Pin NO.	Description	Meter Connection
1	CT-input	CT-P(White)
2		CT-N(Black or Blue)
3	N-in	Grid N <sup>®</sup>
4	L-in	Grid L
9	RS485B	COM Port RS485B2
10	RS485A	COM Port RS485A2

**Note:** <sup>®</sup>For Australian market, installers can connect pin3 to the neutral links/bars.

## 5. Post-installation check

No.	Acceptance criteria	No.	Acceptance criteria
1	The inverter is installed correctly, firmly and reliably.	6	The RS485 communication cable is installed correctly and firmly.
2	The ground wire connected well and the connection is firm and reliable.	7	The cable tie port is trimmed well without leaving sharp corners, meets the requirements of the user.
3	All switches are in the OFF state.	8	All exposed terminals are well protected and there are no vacant ports.
4	All wiring is correct and securely connected.	9	Pay attention to clean up all construction residues.
5	The wiring of the cable is reasonable, meets the requirements, and there is no phenomenon of broken skin.		

## 6. Power on and off steps

**⚠ Note:**

Before turning the inverter on, please make sure the PV input voltage and current are within the MPPT limits.

Follow the steps below to turn the inverter on:

- Switch on the built-in DC isolator at the bottom of the inverter.
- Switch on the PV Array and DC isolator next to your inverter, if you can not find this switch, skip this step.
- Switch on the Solar AC isolator if the inverter is more than 3 meters away from your switchboard.
- Switch on the Solar supply main switch in the switch board.

To shut down your system, follow this guide in reverse order.

## 7. Status of PV grid inverter

Customer can read more information by push button.

Symbol	Description	Explanation	
	Touch button	Single touch	Switch the display interface or the current number plus 1
		Double touch	Enter the setting state or confirm
		Triple touch	Return to the previous display interface
		Hold 5s	The current data returns to the default value
	Inverter status indicator	Red	Fault
		Green	Normal operation
		Red light flashing	Warning
		It can display the basic information of inverter through OLED display screen (PV/AC voltage, PV power, AC current, total power, generating capacity, etc.).	

## 8. Export limitation setting

If the local grid company requires to limit the output power from your inverter systems, we introduce the concept of Export Limit Rate. The ratio of your system output power divided by the rated power of the inverter is called Export Limited Rate. For example, if the local grid company only accepts 8kW from your 10kW system, then the Export Limit Rate of 10kW inverter should be 80%.

## 9. Service and contact

SHEN ZHEN WAET Technology Co., Ltd  
 101-102, Block A Fuyu Residence, Pankeng road (No.108, Qinde Road), Second Industrial Zone, Baihua Community, Guangming street, Guangming District, Shenzhen, P.R. China.  
 Tel: 13802559214  
 Web: www.waeta.cn