

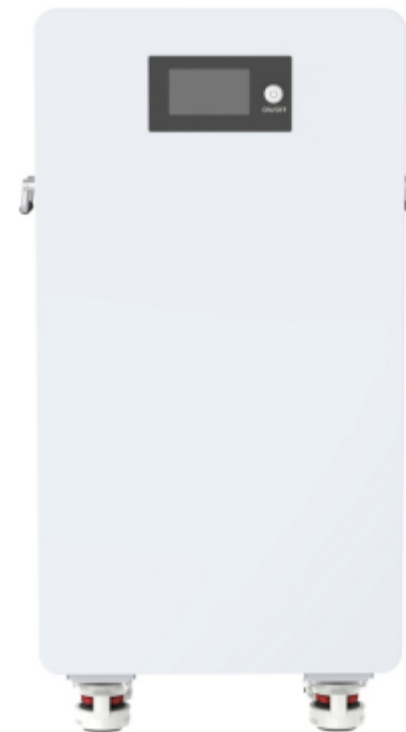

SHEN ZHEN WAET Technology Co., Ltd
101-102, Block A Fuyu Residence, Pankeng road(No.108, Qinde Road)
, Second Industrial Zone, Baihua Community,
Guangmingstreet, Guangming District, Shenzhen, P.R.China.
Tel: 13802559214
Web: www.waeta.cn
E: waetpower@outlook.com



**Residential Energy Storage
Hope 16.0LM-A1 Battery System
User Manual**

About This Document

This document describes the installation, electrical connection, operation, commission, maintenance and troubleshooting of Hope 16.0LM-A1 Battery System (hereafter simply put Hope 16.0L). Before installing and operating Hope 16.0 LM-A1, ensure that you are familiar with product features, functions, and safety precautions provided in this document.

Table of Contents

| | |
|---|-----------|
| 1 Product Overview..... | 1 |
| 1.1 Product Description | 1 |
| 1.2 Appearance..... | 1 |
| 1.2.1 Dimension (unit:mm) | 1 |
| 1.2.2 Introduction to the battery operation panel | 2 |
| 1.3 LCD display information | 3 |
| 1.4 Function and Introduction | 8 |
| 1.5 Battery software upgrade | 10 |
| 1.5.1 Upgrade via USB | 10 |
| 1.5.2 Upgrade via Inverter | 10 |
| 2 Safety | 11 |
| 2.1 Application..... | 11 |
| 2.2 Safety Precautions | 12 |
| 2.2.1 Environment requirements..... | 12 |
| 2.2.2 Operation and Precautions | 12 |
| 2.3 Warning labels | 13 |
| 2.4 Emergency Responses | 14 |
| 3 Storage and Transportation | 15 |
| 3.1 Storage Requirements..... | 15 |
| 3.2 Transportation Requirement..... | 15 |
| 4 Installation..... | 16 |
| 4.1 Installation Environment | 16 |
| 4.2 Installation Required Tools | 16 |
| 4.3 Check..... | 17 |
| 4.3.1 Pre-installation Check | 17 |
| 4.3.2 Check Packing List..... | 17 |
| 4.4 Installation | 18 |
| 4.4.1 Battery Placement..... | 18 |
| 4.4.2 Communication Cable Communication | 18 |
| 4.4.3 Single Battery Installation | 19 |
| 4.4.4 Battery Capacity Expansion Installation..... | 21 |
| 4.4.5 Battery Pack Power Expansion Installation | 22 |
| 4.4.6 Battery Pack Capacity and Power Expansion Installation..... | 23 |
| 5 Power on/off..... | 25 |
| 5.1 Power on..... | 25 |
| 5.2 Power off..... | 25 |
| 6 Maintenance Guide..... | 26 |
| 6.1 Preparation | 26 |
| 6.2 Battery Replacement | 26 |
| 6.3 System Failure Information List and Trouble Shooting Suggestions..... | 26 |
| 7 Technical Specifications..... | 28 |
| Appendix 1 Fault code table | 29 |
| Appendix 2..... | 33 |

1 Product Overview

1.1 Product Description

Hope 16.0LM-A1 consists of 314Ah cells which form 51.2V voltage battery module and 16 cells in serial connection (1P16S). Max parallel number is 48pcs which can expand the capacity to up to 686KWH. Support LCD screen display and setting. For meeting the needs of home storage power supply, batteries and inverters are combined to be home storage solar system with protection functions such as overcharge, over-discharge, over current, over temperature, and short circuit. For serve customers properly, the company has a big data server to facilitate after-sales maintenance, and equipped with APP display function, remote upgrade function and U-disk upgrade function. Additionally, an external integration LCD display allows customers to check the different batteries conditions and read the different batteries details more conveniently.

1.2 Appearance

Hope 16.0LM-A1 consists of battery module (including cells and mechanical parts), battery management system (BMS) as well as power switch and communication terminals. Product appearance as below.

1.2.1 Dimension (unit:mm)

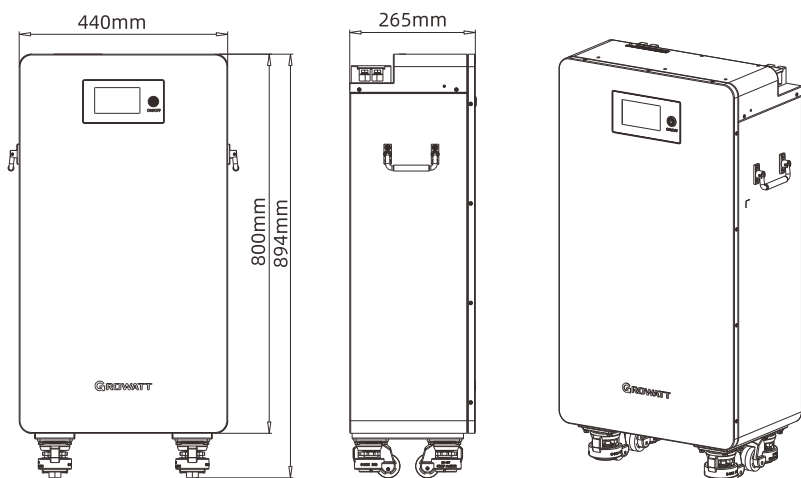

Figure 1: Battery size diagram

1.2.2 Introduction to the battery operation panel

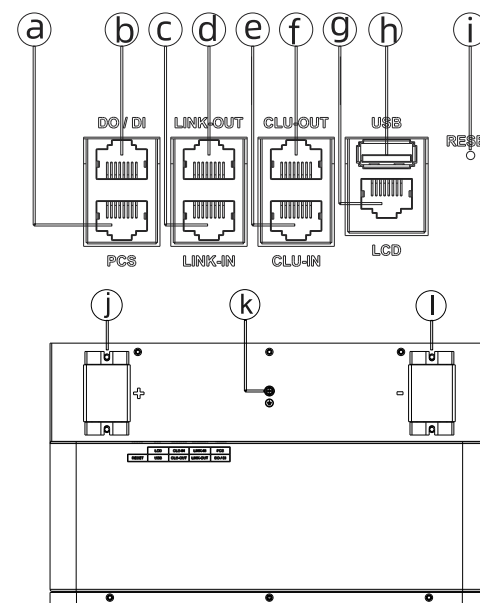

Figure 2: Introduction to the battery operation panel

| Location | Port | Function |
|----------|----------|---|
| a | PCS | Communicate with the inverter |
| b | DO/DI | Emergency signal output/input port |
| c | Link-In | battery parallel communication (CAN/WAKEUP/MASTER) |
| d | Link-Out | battery parallel communication (CAN/WAKEUP/SLAVE) |
| e | Clu-In | clustering communication |
| f | Clu-Out | clustering communication |
| g | LCD | For linking external integration LCD |
| h | USB | USB interface for system upgrade, a mobile phone can't be charged |
| i | Reset | Pressing triggers MCU reset |
| j | P+ | Battery Positive |
| k | GND | GND |
| l | P- | Battery Negative |

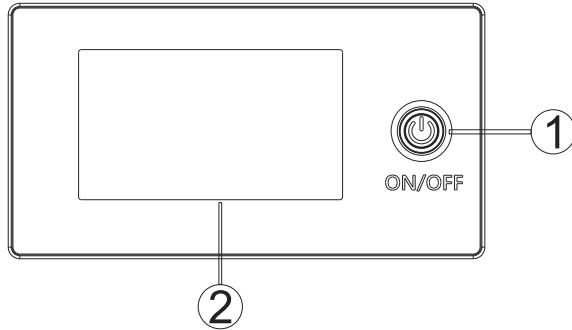

Figure3: LCD Panel drawing

| No. | Name | Color | Description |
|-----|--------|-------|-------------------------|
| 1 | ON/OFF | Green | Power on/off Button |
| 2 | LCD | | Displaying battery data |

1.3LCD display information

The LCD adopts a touch resistive screen. The screen is off by default for 30 seconds. You can light up and switch the screen pages by touching it with your finger. It includes main information, individual information, fault information, equipment information and setting parameters.

| Page information | LCD display |
|---|-------------|
| <p>Real page 1</p> <ul style="list-style-type: none"> ①Master/slave identification ②Battery SOC(%) ③Battery voltage(V) ④Battery current(A) ⑤State | |

| Page information | LCD display |
|--|-------------|
| <p>Real page 2</p> <ul style="list-style-type: none"> ①Battery voltage(V)/current(A) ②Battery SOC(%)/State ③High Cell volt(mV) /Low Cell Volt(mV) ④High cell temp/Low cell temp ⑤Allowable charging current/Allowable discharge current | |
| <p>Real page 3</p> <ul style="list-style-type: none"> ①Cluster address /Cluster number ②parallel address /parallel number ③Load Volt(V) / SOH(%) ④High Cell volt(mV) /Low Cell Volt(mV) ⑤Number of cycles /balance state ⑥Charge MOS state/ Discharge MOS state | |
| <p>Real page 4</p> <ul style="list-style-type: none"> ①High cell temp/Low cell temp ②Environment temp/MOS temp ③Remaining capacity/Full capacity ④Allowable charging current/Allowable discharge current ⑤Cumulative charging capacity/ Cumulative discharge capacity | |
| <p>Cell page</p> <ul style="list-style-type: none"> ①Cell volt 01-04 ②Cell volt 05-08 ③Cell volt 09-12 ④Cell volt 13-16 ⑤Cell Temperature 01-04 ⑥Cell Temperature 05-08 | |

| Page information | LCD display |
|--|-------------|
| <p>Severe page For detailed analysis of fault codes, please refer to Appendix 1</p> | |
| <p>Moderate page For detailed analysis of fault codes, please refer to Appendix 1</p> | |
| <p>Minor page For detailed analysis of fault codes, please refer to Appendix 1</p> | |
| <p>Device info page ① SN ② LCD Ver ③ BMS Ver ④ Fault list (Switch the fault page by using the up and down arrows, For detailed analysis of fault codes, please refer to Appendix 1)</p> | |

| Page information | LCD display |
|--|-------------|
| <p>Setting menu page ① System settings ② Protocol setting ③ Basic setting</p> | |
| <p>System settings page Enter the password 1859 and press OK to enter</p> | |
| | |
| <p>System Settings modification confirmation interface</p> | |

| Page information | LCD display |
|--|-------------|
| <p>Protocol setting page Enter the password 1859 and press OK to enter</p> | |
| <p>Click on different protocols to switch</p> | |
| <p>Parameter Settings Enter You need to enter the password to enter. It is for developers to use.</p> | |

| Page information | LCD display |
|---|-------------|
| <p>Basic setting page ①Low-temperature discharge mark ②Rated capacity setting ③Cycle capacity setting ④SOC setting ⑤Forced restoration Settings ⑥PCS Protocol Settings</p> | |
| <p>Parameter modification interface</p> | |

1.4 Function and Introduction

| Function | Description |
|-------------------------|--|
| APP Display and Upgrade | Display BMS information and upgrade |
| CAN communication | 2 Circuits, with isolation, One for battery parallel communication, the other for communication with inverter |
| Battery in Parallel | Max parallel number is 48pcs |
| SOC Algorithm | Dynamic SOC estimation for battery packs |
| SOP Algorithm | Based on different temperature, The evaluation capacity of voltage and SOC to the maximum output or maximum input at the next moment |
| Running Status Display | LED lights to display Green: System running status |

| Function | Description |
|-----------------------|---|
| Power off | 1.Button Shutdown, 2.No Communication Shutdown, 3.Battery Low Voltage Shutdown 4.When Used in Parallel, it Can Be "One Key Shutdown. |
| Power on | 1.Key On, 2.Charge On, 3.Activate Signal on, 4.When Used in Parallel Can "One Key On". |
| Balanced Management | Improve the consistency of the voltage of each single battery to protect the battery. |
| Voltage Detection | Detect single cell voltage (14-16 strings) or total voltage (2 circuits). |
| Current Detection | Battery charging current, discharging current detection. |
| Temperature Detection | Total 8 circuits. 6 circuits for battery temperature detection, 1 circuit for Mosfet temperature detection, 1 circuit for battery internal ambient temperature detection. |
| Protection | overcharge protection, over discharge protection, over-voltage protection, high temperature protection, low temperature protection, short circuit protection and hardware fault protection, etc. with record function for the fault alarm and protection, which is convenient for after-sales viewing and analysis of problems. |
| Pre-charge Control | Charging low-voltage batteries with low current. |
| Pre-discharge Control | Pre-charge the inverter capacitors. |
| Interface | Same port . |

1.5 Battery software upgrade

1.5.1 Upgrade via USB

1. Copy the upgrade file into the U disk.
2. Turn battery off, access U disk.
3. Turn on battery and successfully enter the upgrade state, the RUM led will blink for 3 seconds at the same time.
4. If the battery starts properly, the upgrade is complete.

Note: Choose the USB upgrade mode, there must be no other files in the U disk, otherwise the upgrade will not be possible or the upgrade error.

1.5.2 Upgrade via Inverter

1. Connect to WiFi monitor for remote upgrade through inverter.
2. The LCD displays the upgrade screen, Show Progress Bar.
3. When the Progress Bar reaches 100% , the upgrade is complete.

Note: Inverter remote upgrade mode can only upgrade the battery host, After the host upgrade is completed, the host will upgrade all slaves.

2 Safety

Safety information contained in this section must be observed at all times when working on or with batteries.

For safety, installers are responsible to familiarize themselves with this manual and all warnings before installation.

2.1 Application

Please read the product manual and the warning signs on the surface of the battery box carefully before using the battery. Improper use of the battery may cause overheating and damage to the battery. The company does not assume any responsibility for any accidents caused by improper operation. In order to use and dispose of the battery safely, please read the operating instructions carefully before use:

- Keep the batteries away from heat sources, high voltage places and long periods of sunlight exposure.
- Batteries must not be thrown into water or fire.
- Do not reverse the positive and negative terminals of the battery.
- Do not use metal to short the positive and negative terminals of the battery.
- Avoid excessive physical shocks and impacts to the battery, do not hit, drop or step on the battery.
- It is strictly forbidden to disassemble or assemble the battery privately without the permission and guidance of the manufacturer.
- Cannot mix other batteries of different manufacturers, types and models.
- Do not use or store in high temperature environments, as this may cause the battery to heat up, catch fire or have a reduced service life.
- Charge the battery promptly (within 15 days) after it runs out of charge.
- Please use the matching or recommended professional lithium battery charger.
- Stop using the battery if it has abnormal conditions such as odor, discoloration, noise, liquid leakage, or serious deformation.
- If electrolyte leaks into the skin or eyes, flush with water and seek immediate medical attention.
- Please place the battery out of the reach of pets and children, and prohibit children from touching the battery.
- Below 0°C, due to the low temperature performance of the battery, please reduce the power to use, a battery pack with a load of 2.5KW or less.

2.2 Safety Precautions

2.2.1 Environment requirements

- Do not expose the battery to temperature above 60°C, or heat sources.
- Do not install or use the battery in wet locations, moisture, corrosive gases or liquids, such as bathroom.
- Do not expose the battery to direct sunlight for extended periods of time.
- Place battery in safe place away from children and animals.
- Battery power terminals shall not touch conductive objects such as wires.
- Do not dispose the batteries in fire, which may cause an explosion.
- The PACK shall not come in contact with liquids.
- The PACK can only be installed indoors. Regarding indoor installation, please do not install it in the bedroom, living room, kitchen, etc.

2.2.2 Operation and Precautions

- Do not touch the PACK with wet hands.
- Do not disassemble the PACK without permission.
- Do not crush, drop or puncture the PACK and battery.
- Dispose the batteries according to local safety regulations.
- Store and recharge battery in accordance with this manual.
- Ensure the connection of ground wire reliable.
- Remove all metal objects such as watches and rings that could cause a short-circuit before installation, replacement and maintenance.
- The Pack shall be repaired, replaced or maintained by skilled personal that has been recognized.
- When storing or handling batteries, do not stack batteries without package.
- Do not break the battery, the released electrolyte may be toxic and is harmful to skin and eyes.
- Packaged batteries should not be stacked more than specified number stipulated on the packing case.
- Do not use damaged, failed or deformed batteries, which may lead to high temperature or even dangerous accidents. Continued operation of damaged battery may result in electrical shock, fire or even worse.

2.3 Label Description

| Symbols | Description |
|---|---|
|  | Do not dispose in trash |
|  | can be recycled |
|  | Certification in European union area |
|  | Electric shock hazard |
|  | Explosive gas |
|  | May leak corrosive electrolyte |
|  | Heavy enough to cause severe injury |
|  | Keep the Pack away from children |
|  | Make sure the battery polarity well connected |
|  | Do not expose to fire |
|  | Operate according to Manual |

| LiFePO ₄ Battery | |
|---|----------------|
| Model Name | Hope 16.0LM-A1 |
| Nominal Voltage | 51.2V |
| Rated Capacity | 314Ah |
| Rated Energy | 16KWh |
| Max Charge Current | 150A |
| Max Discharge Current | 200A |
| Ingress Protection | IP20 |
| Charge Temperature | 0°C ~ 60°C |
| Discharge Temperature | -20°C ~ 60°C |
|  | |
| X Made In China | |

Figure 5: Nameplate

2.4 Emergency Responses

Manufacturer takes foreseeable risk scenarios into consideration and is designed to reduce hazards and dangers. However, if the following situation occurs, do as below:

| Situation Occurs | Treatment Solution |
|------------------|--|
| Leakage | <ol style="list-style-type: none"> 1. Avoid touch of leaking liquid or gas. If you touch the leaking electrolyte, do as below immediately. 2. Inhalation: Evacuate the contaminated area, and seek medical help. 3. Eye contact: Rinse eyes with flowing water for 15 minutes, and seek medical help. 4. Skin contact: Rinse contacted area thoroughly with soap and water, and seek medical help. 5. Ingestion: Vomiting, and seek medical help. |
| Fire | If the battery is on fire, try to extinguish the fire with fire fighting sand and evacuate people due to the situation. |
| Wet Packs | If pack is flooded or submerged, do not use it. Contact Manufacturer for technical assistance immediately. |
| Damaged PACKS | Damaged pack are dangerous and must be handled with special attention. They are no longer suitable for use and may cause danger to people. If the pack damaged, stop use it and contact the manufacturer. |

3 Storage and Transportation

3.1 Storage Requirements

Place the battery follow the identification on the packing case during storage.

Do not put the battery upside down or sidelong.

The defective pack needs to be separated from other Batteries.

The storage environment requirements are as follows:

1. Install the battery in a dry and clean place with proper ventilation.
2. The storage temperature for a short week is between -20°C to 60°C.
3. If you store the pack over a long period of six months, the storage temperature is between 0°C to 35°C,
4. relative humidity: 10%-60%RH.
5. Place the battery away from corrosive and organic substances (including gas exposure).
6. Free from direct exposure to sunlight and rain.
7. At least two meters away from heat sources (such as a radiator), free from exposure to intensive infrared radiation.

If the battery has not been used for more than six months, it needs to be charged, the charging procedure is as follows:

1. 1) Identify the PACK that needs charging.
2. 2) Refer to quick installation guidance, complete the installation and wire connection. Ensure BATTERY in off status during all the steps.
3. 3) Activating the inverter, activating the battery and starting charging.
4. 4) When the RUN_LED is always on, the LCD SOC progress bar blinks, indicating that it is charging normally.
6. 5) When the LCD SOC displays 100%, it is fully charged.

3.2 Transportation Requirement

PACK has been certified in UN38.3 (Section 38.3 of the sixth Revised Edition of the Recommendations on the Transport of Dangerous Goods: Manual of Tests and Criteria) and SN/T 0370.2-2009 (Part 2: Performance Test of the Rules for the Inspection of Packaging for Exporting Dangerous Goods). PACK is classified as category 9 dangerous goods.

The PACK shall not be transported with other inflammable, explosive or toxic substances; Ensure the original Package and label complete and recognizable.

Prohibit direct exposure to sunlight, rain, condensing water caused by temperature difference and mechanical damages.

There will be a drop in capacity during transportation and storage.

Transportation temperature is between -10°C to 45°C, relative humidity: 10%~90%RH.

Installation 4

Ensure to read the Guidance before installation in order to understand product information and safety cautions.

Operators should be well trained technicians and fully understand the whole photovoltaic system, grid network, working principle and national regional standards.

Installers must use insulating tools and wear safety equipment.

Device damages caused by failure to comply with storage, transportation, installation and use requirements specified in Guidance are not covered by Warranty.

The PACK can only be installed indoors. Regarding indoor installation, please do not install it in the bedroom, living room, kitchen, etc.

Different types of batteries are not recommended to be mixed and used in parallel.

The battery system cannot be installed, dismantled, and maintained when it has been powered on.

4.1 Installation Environment

The ambient temperature for the installation of the battery system shall be above 0°C, below 40°C, and the humidity shall between 10% -95%.

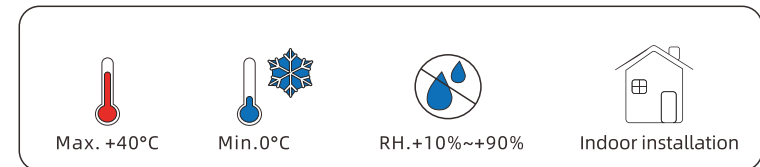
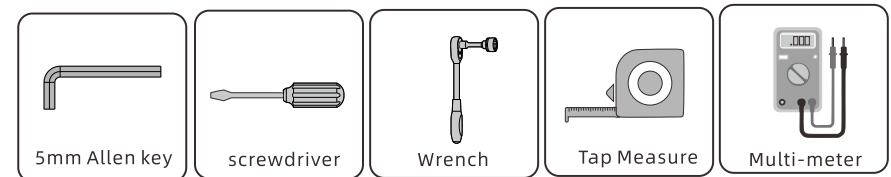

Figure 5: Installation Environment Requirements

4.2 Installation Required Tools

The following tools are required to install the pack:



It is recommended to wear the following safety gear when dealing with the pack.

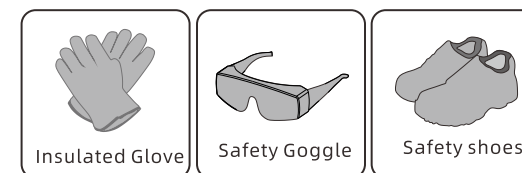

4.3 Check

4.3.1 Pre-installation Check

| | |
|-------------------|---|
| Check the package | Check the PACK package before opening it, if any abnormality is detected, do not open the package and contact your supplier. |
| Check the power | Check and confirm the PACK is powered off before installation. |
| Check deliverable | Check the quantity of all parts inside according to the package list. If there is any part missing or damaged, please contact your distributor. |

4.3.2 Check Packing List

| Hope 16.0LM-A1 Battery Pack | | | | | |
|-----------------------------|-----------------------------|-------|------|---------------|-------|
| Item | Part Name | Qty | Item | Part Name | Qty |
| 1 | Hope 16.0LM-A1 Battery Pack | 1 pcs | 5 | SC35-8 lug | 4 pcs |
| 2 | User Manual | 1 pcs | 6 | + power cable | 1 pcs |
| 3 | Network cable A | 1 pcs | 7 | + power cable | 1 pcs |
| 4 | warranty card | 1 pcs | | | |

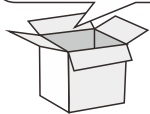
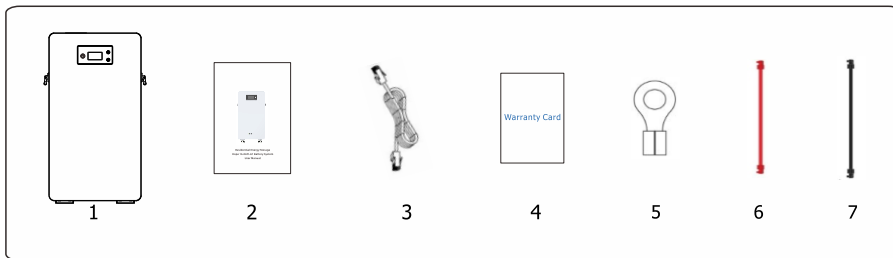

4.4 Installation

4.4.1 Battery Placement

- 1) Please install indoors and ensure the level of the ground.
 - 2) The maximum quantity of stacking battery pack is 6, only support to horizontally mounted.
- Make sure the batteries are mounted in the correct orientation. Please refer to the picture below (√ means acceptable, X means unacceptable).

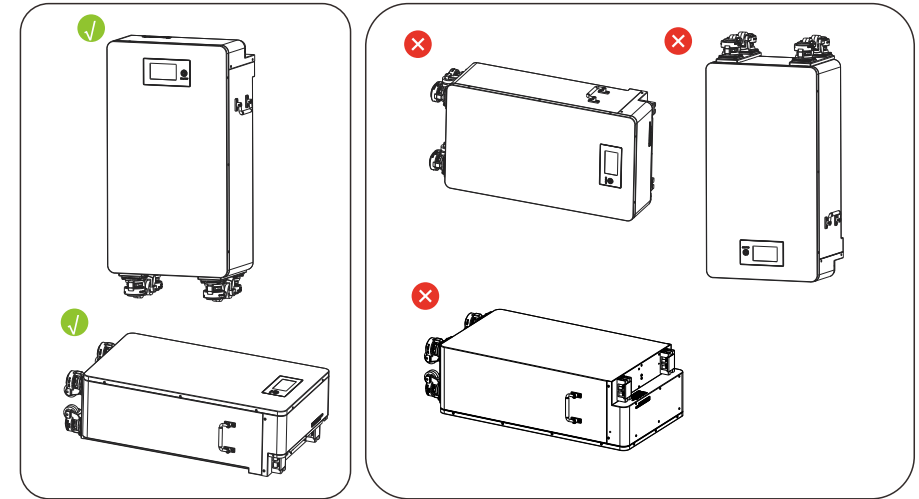

4.4.2 Communication Cable Communication

Please wear an anti-static wrist strap, anti-static gloves, and goggles. It is recommended that the power line and communication line between the battery and the inverter should not exceed 2 meters. inverter Communication interface definition:

| Item | Crystal head picture | Serial no. | Definition |
|------|----------------------|------------|------------|
| PCS | | 1 | RS485_B |
| | | 2 | RS 485_A |
| | | 3 | GND_COM |
| | | 4 | CAN_H |
| | | 5 | CAN_L |
| | | 6 | GND_COM |
| | | 7 | Wake- |
| | | 8 | Wake+(5v) |

4.4.3 Single Battery Installation

Make sure the battery is in off mode and the battery breaker is off Ensure there are no tangled cables after battery wiring.

Step 1: Castor mounting

The four casters of the base are installed as shown in the figure, Rotate the pulley and secure the caster, Prevent caster rolling.

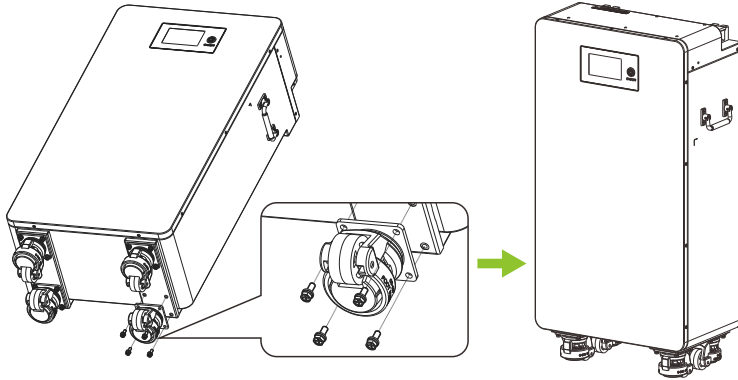

Figure 6: Caster installation diagram

Step 2: Ground installation

Fix the ground wire to the ground terminal with an M4 screw and fix the other end to the inverter. Note that the cross-sectional area of the ground wire is 16mm².

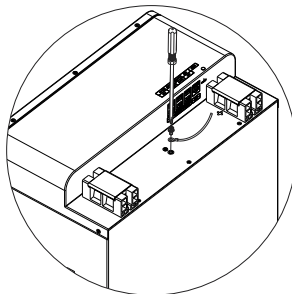

Figure 10: Ground diagram

Step 3: Insert the network cable into the battery port.

1. Insert network cable A into the inverter port of the battery, and the other end of the network cable into the network port of the inverter.

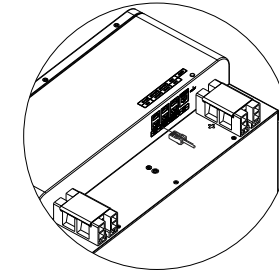

Figure 11: Network cable connection diagram

Step 4: Connecting Power Cable

1. Fix the OT terminal of the power cable to the pair of "+/-" terminals of the battery.
2. Put the plastic cover back.
3. Fix the other end to the breaker and then connect to the inverter.

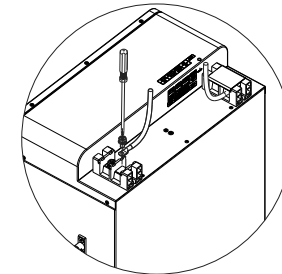

Figure 12: Power line connection diagram

When connecting the power cable, make sure the direction of OT terminal is correct. Don't stack two OT terminals on one power port.

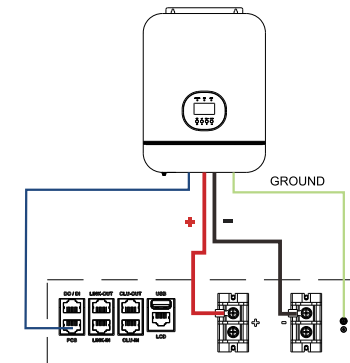

Figure 13: Single Battery Installation Diagram

- 1) The battery is not allowed to be wired in the running state, and the battery should all be off before installation.
- 2) Please install the communication line first, then protect the unused ports and USB ports against dust, and finally install the power cable.
- 3) To ensure the safety, don't forget to connect ground wire .
- 4) We recommend installing a circuit breaker between the inverter and the battery. For the specifications of the circuit breaker, we recommend using a molded case circuit breaker with a rated operating voltage greater than 80Vdc and a rated operating current greater than 250A.

4.4.4 Battery Capacity Expansion Installation

- * Ensure all batteries are in off mode and battery breaker are off.
- * Ensure there are no tangled cables after battery wiring.
- * Max Capacity Expansion parallel is 10pcs to create a 16.0kw expanded energy storage system.

Step 1 Connect network cable

1. Insert the network cable A into the inverter port of battery 1, and the other end insert into the BMS network port of the inverter .Connect the first and last battery lines 2 to the inverter.
2. Use network cable B to connect the LINK-OUT port of battery 1 to the LINK-IN port of battery 2 , Connect the rest of the batteries in the same way until the last battery is connected.

Step 2 Connect Ground

Connect the ground terminal of each battery to the ground strip.

Step 3 Connect Power Cable

Connect the +/- terminals of each battery to the +/- terminals of the next battery, and then connect the wires to the inverter.

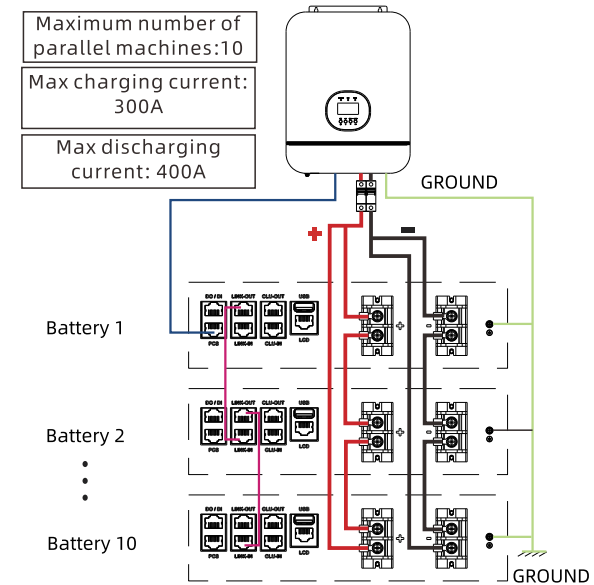

Figure 14: Capacity Expansion Installation Diagram

- 1) The battery is not allowed to be wired in the running state, and the battery should all be off before installation.
- 2) Refer to Figure 14 for power cable wiring.
- 3) Please install the communication line first, then protect the unused ports and USB ports against dust, and finally install the power cable.
- 4) We recommend installing a circuit breaker between the inverter and the battery. For the specifications of the circuit breaker, we recommend using a molded case circuit breaker with a rated operating voltage greater than 80Vdc and a rated operating current greater than 400A.

Note: When more than two batteries are connected in parallel, the maximum working current reaches 400 A. You are advised to connect the power cables of the first and last two batteries to the inverter to ensure more balanced charging and discharging of batteries and more security.

4.4.5 Battery Pack Power Expansion Installation

- * Make sure all batteries are in off mode and the battery circuit breaker is off.
- * Make sure there are no tangled cables after the battery wiring.
- * Max Output Power Expansion parallel is 8pcs to create a 57kw expanded energy storage system

Step 1: Connect Network Cable

1. Insert one end of the network cable A into the inverter interface of battery 1 and the other end into the BMS network port of the inverter.

2. Connect the LINK-OUT connector of battery 1 and the LINK-IN connector of battery 2 using network cable B. Connect the rest of the batteries in the same way until the last battery is connected.

Step 2: Connect the Ground Wire

Connect the ground terminal of each battery to the grounding strip.

Step 3: Connect Power Cable

Connect the +/- terminal of each battery into the +/- terminal of the latter battery separately, and then connect the wires to the inverter.

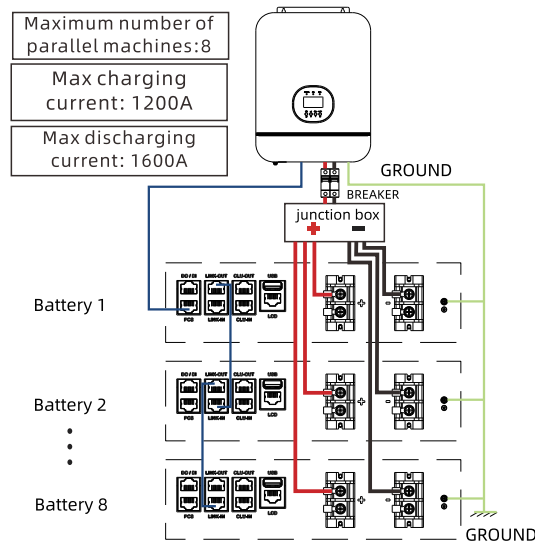

Figure 15: Installation Diagram for Power Expansion

- 1) The battery is not allowed to be wired in the running state, and make sure all batteries are in off mode before installation.
- 2) Refer to Figure 15 for power cable wiring.
- 3) Please install the communication line first, then protect the unused ports and USB ports against dust, and finally install the power cable.
- 4) We recommend installing a circuit breaker between the inverter and the battery. For the specifications of the circuit breaker, we recommend using a molded case circuit breaker with a rated operating voltage higher than 80Vdc, the rated working current is determined by the power. It is recommended to connect a battery pack to a 200A circuit breaker, and connect multiple battery packs to 400A*n circuit breaker.

4.4.6 Battery Pack Capacity and Power Expansion Installation

- * Ensure all batteries are in off mode and battery breakers are off.
- * Ensure there are no tangled cables after battery wiring.
- * Support up to 48 battery packs connected in parallel to form a 114KW expanded energy storage system

Step 1: Connect The Network Cable

1. Insert one end of the network cable A into the inverter interface of battery 1 and the other end into the BMS network port of the inverter.
2. Connect the LINK-OUT connector of battery 1 and the LINK-IN connector of battery 2 using network cable B. Connect the rest of the batteries in the same way until the last battery is connected.
3. Connect CLU-OUT port of master battery in main cluster and CLU-IN port of master battery in Slave Cluster, connect rest of batteries in the same way until the last battery is connected.

Step 2 Connect The Ground Wire

Connect the ground terminal of each battery to the grounding strip.

Step3 Connect The Power Cord

Connect the +/- terminal of each battery into the +/- terminal of the Junction box separately, and then connect the wires to the inverter.

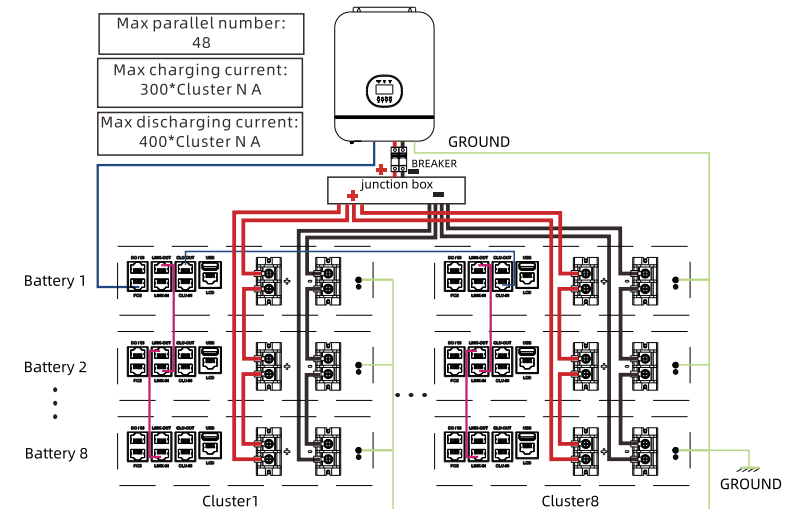

Figure 16: Installation Diagram for Capacity Expansion

- 1) The battery is not allowed to be wired in the running state, and the battery should all be off before installation.
- 2) Refer to Figure 16 for power cable wiring.
- 3) Please install the communication line first, then protect the unused ports and USB ports against dust, and finally install the power cable.
- 4) We recommend installing a circuit breaker between the inverter and the battery. For the specifications of the circuit breaker, we recommend using a molded case circuit breaker with a rated operating voltage higher than 80Vdc, the rated working current is determined by the power. It is recommended to connect a battery pack to a 200A circuit breaker, and connect multiple battery packs to 400A*n circuit breaker.

5 Power on/off

The installation and use of batteries involve much specialized knowledge. Therefore, technicians should be given appropriate technical training and obtain operational certificates in compliance with local laws and regulations. Please ensure technicians have obtained training certificate before operation. Please stand on dry insulating objects and do not wear conductive material such as watches and necklace during operation. Insulated tools should be used. Do not contact any positions with voltage potential difference. Prohibition sign should be hung on the battery: " Non-professionals, do not touch" . If any abnormalities occur during the startup phase, power off the pack immediately. After problem confirmed, proceed again. Make sure the inverter is turned off before checking the pack.

5.1 Power on

When multiple batteries are connected in parallel or multiple clusters of batteries are connected in parallel, press one of the battery power buttons and all the batteries connected in parallel can be turned on.

| Power on the PACK by pressing power button(t>1S) | | |
|--|---|--|
| Item | procedures | Acceptation criteria |
| 1 | Connect battery and inverter | Make sure the wiring harnesses are well connected. |
| 2 | Turn on breaker of battery | Make sure breaker of battery is ON. |
| 3 | Press power switch for 1 second and observe LED and LCD indication on panel | 1.if indication of RUN and SOC is ON, pack is powered on successfully. 2.If the LCD displays the fault code and the MOS is not turned on, it indicates that the packaging has a fault and should be solved before restarting. |
| Power on pack by inverter | | |
| 1 | Connect inverter and battery | Make sure the wiring harnesses are well connected. |
| 2 | Turn on breaker of battery | Make sure breaker of battery is ON |
| 3 | Power on inverter for charging battery | 1.if indication of RUN is ON, pack is powered on successfully. 2.If the LCD displays the fault code and the MOS is not turned on, it indicates that the packaging has a fault and should be solved before restarting. |

5.2 Power off

Press the power switch for 3 seconds and release it, battery off, LED lights off. If multiple batteries are connected in parallel, only press the power switch of any one of the batteries for 3 seconds and then release it, the other batteries can be turned off.

Maintenance Guide 6

6.1 Preparation

Tools like safety gloves, cross head driver and socket wrench should be prepared. Turn off and turn on new PACK .

1. If the PACK is power-off. Press power button for 1 second to turn on.
 2. If the PACK is power-on. Press power button 3-5 seconds to turn off.
- Before maintaining the battery, turn off the breaker and press power button 3-5 seconds to make sure the battery is power-off. Follow the installation and wire connection procedures specified above. Ensure wires are properly connected before turn the breaker on. After that, turn on the breaker and press power button of any battery for 1 second to check if the system normal works.

6.2 Battery Replacement

- Wear safety gloves.
- Open the breaker and power off the battery.
- Remove your safety screw under the power supply, and disconnect the power cord and CAN.
- communication line of the battery.
- Remove the safety part at the left end of the battery and lift the battery upward.
- Put the battery into the packing box according to the repair procedure and transport the battery
- to the designated repair site.
- Install new battery based on procedure specified in Section 4.

6.3 System Failure Information List and Trouble Shooting Suggestions

| Error code | Error Description | Error Cause | Suggested Actions |
|------------|------------------------------------|--|--|
| 2 | Discharge under voltage protection | Cell voltage / battery voltage below the threshold of under voltage protection | there is no safety risk, but user should stop discharging and arrange charging, |
| 3 | Charge over voltage protection | cell voltage / battery voltage above the threshold of over voltage protection | There is safety risk.user should stop charging,and make it in idle or discharging until recoving to normal status. |

Technical Specifications 7

Functional parameters of Hope 16.0LM-A1 are as below:

| Error code | Error Description | Error Cause | Suggested Actions |
|------------|--------------------------------|---|---|
| 60 | External communication failure | Failed communication for battery and inverter | 1.there is no safety risk, but user should stop using. 2.Check whether communication between inverter and battery is normal. 3.if battery and inverter communication failed, but ensure communication wire connection well. please contact installer for repairing battery. |
| 59 | Internal communication failure | Communication loss of two battery packs in parallel | Check CAN connection of link-in and link-out between two battery PACKS. |
| 10 | Parallel failure | There is alarm in parallel mode | 1.Check CAN connection of batteries. 2.Check wire connection of batteries. |
| 6 | Dicharge short circuit | External short circuit of battery | 1.Safety risk exist,please stop using it. 2.User need contact installer for repairing |
| 21 | Pre-charge short circuit | Different firmware version | 1.Safety risk exist,please stop using it. 2.User need contact installer for updating the same firmware version. |
| 20 | Pre-charge timeout | | |
| 9 | Parallel ver failure | | |
| 36 | Main circuit fault | BMS main power circuit fault | 1.Safety risk exist,please stop using it. 2.User need contact installer for repairing. |
| 12 | MOS control fault | After turn off mosfet, there is still current. | 1.Safety risk exist,please stop using it. 2.User need contact installer for repairing |

| No. | Items | Specification |
|-----|---|--|
| 1 | Battery Module | Hope 16.0LM-A1 |
| 2 | Rated Capacity/Energy | 314Ah/16.0kWh |
| 3 | Nominal Voltage | 51.2V |
| 4 | Operating voltage | 40 - 58.4V |
| 5 | Max.charging current(25°C) | 150A |
| 6 | Max.discharging current(25°C) | 200A |
| 7 | Max peak current | 700A 200us |
| 8 | Battery Type | LiFePo4 |
| 9 | Operative Charging Temperature Range | 0°C~60°C |
| 10 | Operative Discharging Temperature Range | -20 ~ 60°C |
| 11 | Storage Conditions | -20 ~ 60°C Recommended storage temperature: -10~35°C Relative Humidity 10%-60%RH no condensation |
| 12 | Cooling | Natural Cooling |
| 13 | Dimension(W / D / H) | 440/ 265 / 894 mm |
| 14 | Net Weight | 120±2Kg |
| 15 | Gross Weight | 130±2Kg |
| 16 | Installation Type | Floor hanging |
| 17 | Ingress Protection | IP 20 |
| 18 | Safety Certificate | CE(EMC)/UN38.3/MSDS/ROHS/IEC 62619 |
| 19 | Communication port | CAN/RS485 |
| 20 | Max.Parallel number | 48 pcs |

1 Fault code table Appendix

| No | code |  | remark |
|--------------|------|---|---|
| Minor | | | |
| 1 | 51 | SOC Low | SOC lows |
| 2 | 60 | Ex-Comm | The external communication is offline |
| 3 | 55 | Over Cell Volt | The voltage of the unit is too high |
| 4 | 52 | Under Total Volt | The total voltage is too low |
| 5 | 53 | Over Total Volt | The total voltage is too high |
| 6 | 54 | Under Cell Volt | The voltage of the unit is too low |
| 7 | 56 | Shut-Down Alarm | Shutdown alarm |
| 8 | 57 | OCC | The charge over current alarm is generated |
| 9 | 58 | OCD | The discharge over current 1 generates an alarm |
| 10 | 61 | Large Total Volt | Large internal and external pressure difference alarm |
| 11 | 63 | UTC | Low charging temperature |
| 12 | 64 | UTD | Low discharging temperature |
| 13 | 65 | OTC | high charging temperature |
| 14 | 66 | OTD | high discharging temperature |
| 15 | 69 | Large Chg-Cir | Charge circulation warning inside the system |
| 16 | 70 | Large Dsg-Cir | System internal discharge circulation warning |
| 17 | 71 | MOS OT | The temperature of the MOS tube is too high |
| 18 | 72 | Large Cell Diff | The unit pressure difference is large |
| 19 | 73 | Large Temp Diff | Large single temperature difference |
| 20 | 75 | ENV-OT | ambient temperature is too high |

| No | code |  | remark |
|-----------------|------|---|--|
| 21 | 80 | Large Num | The number of parallel machines is too large |
| 22 | 81 | Upgrade | updating |
| Moderate | | | |
| 1 | 67 | OCP | Charge over power |
| 2 | 68 | ODP | Discharge over power |
| 3 | 76 | Clu-Comm | inter cluster communication failed |
| 4 | 77 | MCU SC | MCU short circuit |
| 5 | 78 | AFE SC | AFE short circuit |
| 6 | 2 | Under Total Volt | Total voltage low protection |
| 7 | 3 | Over Total Volt | Total voltage high protection |
| 8 | 4 | Under Cell Volt | Single voltage low protection |
| 9 | 7 | OCC | Charging current large protection |
| 10 | 8 | OCD | Discharge current large 1 protection |
| 11 | 13 | UTC | Low charging temperature protection |
| 12 | 14 | UTD | Low discharge temperature protection |
| 13 | 15 | OTC | High charging temperature protection |
| 14 | 6 | OTD | High discharge temperature protection |
| 15 | 17 | Pall OCC | Parallel Charge over current protection |
| 16 | 18 | Pall OCD | Parallel Discharge over current protection |
| 17 | 19 | Addr Overlap | parallel address is identical |
| 18 | 34 | Clu OCC | cluster Charging over current protection |
| 19 | 35 | Clu OCD | cluster discharge overs current protection |

| No | code |  | remark |
|---------------|------|---|--|
| 20 | 10 | Large Temp Diff | Large single temperature difference protection |
| 21 | 41 | ENV OT | High ambient temperature |
| 22 | 43 | Clu Overlap | Inter cluster heavy sign fault |
| 23 | 44 | AFE OTC | AFE charging over temperature |
| 24 | 45 | AFE UTC | AFE charging low temperature |
| 25 | 46 | AFE OTD | AFE discharging over temperature |
| 26 | 47 | AFE UTD | AFE discharging low temperature |
| 27 | 59 | Inter-Comm Can | The internal can is disconnected |
| 28 | 5 | Over Cell Volt | Single voltage high protections |
| severe | | | |
| 1 | 6 | SCD | Short-circuit protection |
| 2 | 9 | Pall-Ver | Parallel version inconsistency protection |
| 3 | 10 | Pall-Fail | Parallel failure protection |
| 4 | 11 | Large Total Volt | Large internal and external pressure difference protection |
| 5 | 12 | MOS CTL-Fail | MOS tube control fail-safe |
| 6 | 20 | Pre-fail | Pre-charge failure |
| 7 | 21 | Pre-SC | Pre-charge short circuit |
| 8 | 22 | AFE Comm | AFE is offline |
| 9 | 23 | Cell Comm | Cell voltage offline |
| 10 | 24 | Temp Comm | cell temperature offline |
| 11 | 25 | TotalVolt Sample | Total voltage sampling failure |
| 12 | 26 | Temp SC | Temperature short circuit |
| 13 | 27 | LoadVolt Sample | External total pressure sampling failure |

| No | code | | remark |
|---------------|------|-----------------|--|
| 14 | 28 | Eeprom Fail | Parameter loading failed |
| 15 | 29 | AFE OV | AFE over voltage protection |
| 16 | 30 | AFE UV | AFE under voltage protection |
| 17 | 31 | AFE OCC | AFE charge over current protection |
| 18 | 32 | AFE OCD1 | AFE discharge over current protection |
| 19 | 33 | MS_Volt Diff | Large master/slave pressure difference |
| 20 | 36 | Bus Open | The main circuit is open |
| 21 | 37 | AFE OCD2 | AFE discharge over current level 2 |
| 22 | 38 | MOS OT | MOS tube over temperature protection |
| 23 | 42 | Clus Ver | Versions between clusters are inconsistent |
| 24 | 1 | Soft Start Fail | Software startup failure |
| 25 | 74 | DC_fault | No DC current alarm is generated |
| action | | | |
| 1 | 151 | BMS_Pwr | System 0 is powered on and system 1 is powered off |
| 2 | 152 | PreChg | Pre-charge action: 0 off, 1 on |
| 3 | 153 | PreDsg | Pre-release action: 0 off, 1 on |
| 4 | 154 | Chg | The charging MOS operates: 0 turns off, 1 turns on |
| 5 | 155 | Dsg | The discharge MOS operates, with 0 off and 1 on |
| 6 | 200 | TimeSet | Time setting |

Appendix 2

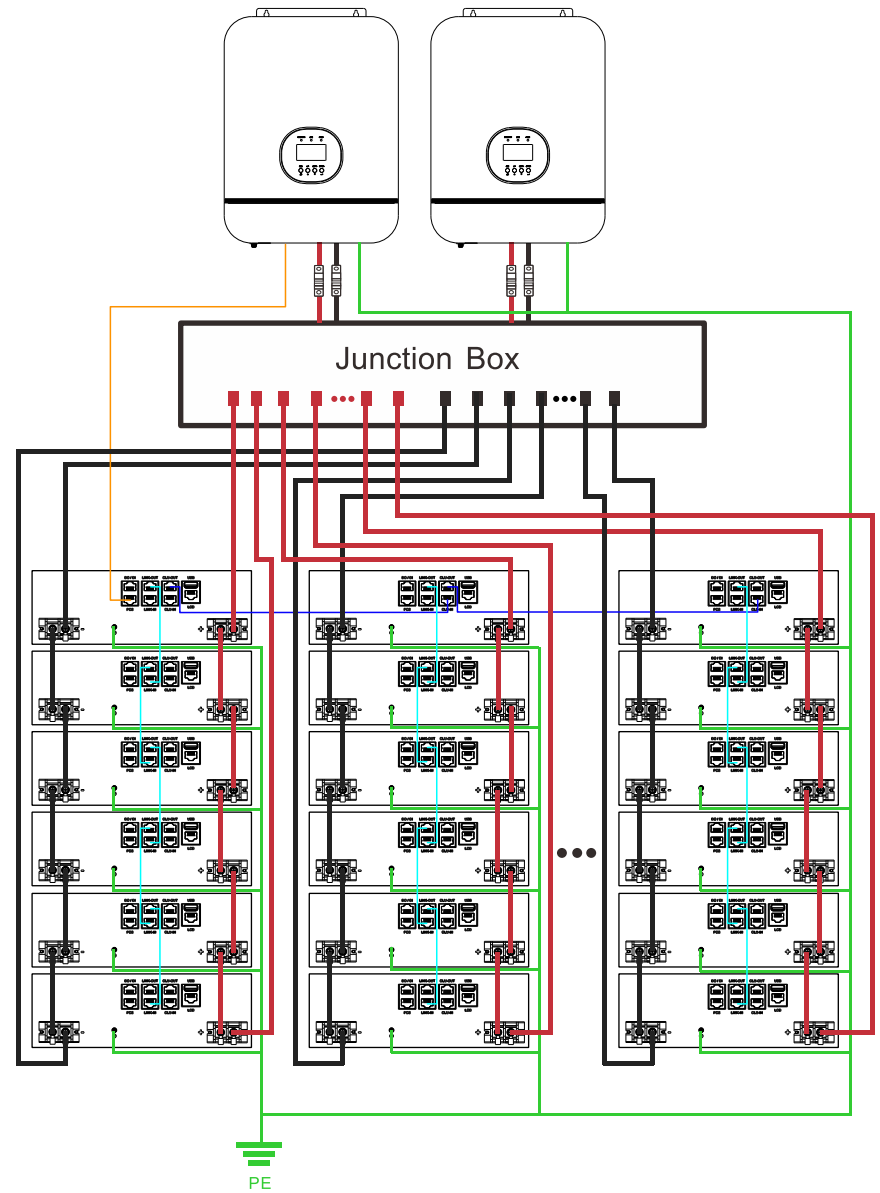

Figure 17: Parallel machines effect drawing