

**Off Grid Solar Inverter
SPF 3500 ES Lite**

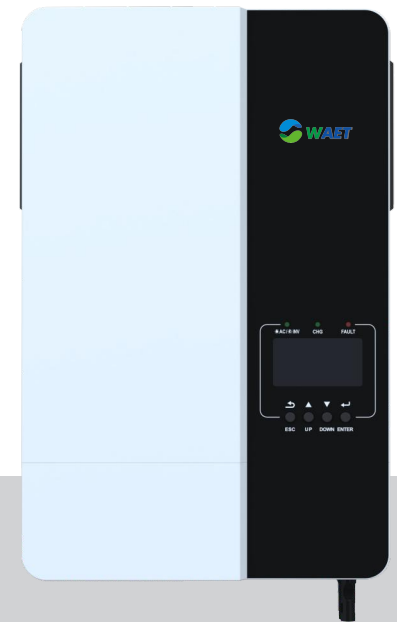

Table Of Contents

1. Information on this Manual	1
1.1 Validity	1
1.2 Scope	1
1.3 Target Group	1
1.4 Safety Instructions	1
2. Product Overview	2
2.1 Product Features	2
2.2 Panel and Port Definitions	3
3. Installation Instructions	4
3.1 Accessory list	4
3.2 Points for attention	4
3.3 Battery Connection	5
3.3.1 Wiring preparation	5
3.3.2 Battery power cable connection	5
3.3.3 Lithium battery communication cable connection	6
3.4 AC Connection	7
3.4.1 Connection preparation	7
3.4.2 AC Input/GEN/Output wires Connection	7
3.5 PV Connection	9
3.5.1 Connection preparation	9
3.5.2 PV cable Connection	9
3.6 Communication Connection	10
3.7 Dry Contact Signal	10
3.8 Wiring system for inverter	11
4. Operation	12
4.1 Power ON/OFF	12
4.2 Display Panel Introduction	12
4.2.1 LCD Display Icons	13
4.2.2 Display Information	14
4.2.3 Operating Mode Description	16
4.3 LCD parameter setting	17
5. Parallel Installation Guide	23
5.1 Parallel accessories	23
5.2 Points of Attention for Parallel	23
5.3 Wire Connections	23
5.3.1 Single-phase parallel wire connection	23
5.3.2 Three-phase parallel wire connection	25
5.4 Parallel Example	27
5.5 Parallel setup and display	28
5.6 Example of a parallel system diagram	29
6. Fault Reference Code	31
6.1 Fault Reference Code	31
6.2 Warning Indicator	32
7. Specifications	33
7.1 Line Mode Specifications	33
7.2 Inverter Mode Specifications	34
7.3 Charge Mode Specifications	35
7.4 General Specifications	35
8. Appendix	36
Appendix I. Fault information and processing	37
Appendix II Restore factory settings	38
Appendix III Battery Equalization	38
Appendix IV Routine maintenance	40
Appendix V WIFI Monitoring	40

1. Information on this Manual

1.1 Validity

This manual is valid for the following devices:

- ▶ SPF 3500 ES Lite

1.2 Scope

This manual describes the assembly, installation, operation and troubleshooting of this unit. Please read this manual carefully before installations and operations.

1.3 Target Group

This document is intended for qualified persons and end users. Tasks that do not require any particular qualification can also be performed by end users. Qualified persons must have the following skills:

- ▶ Knowledge of how an inverter works and is operated
- ▶ Training in how to deal with the dangers and risks associated with installing and using electrical devices and installations
- ▶ Training in the installation and commissioning of electrical devices and installations
- ▶ Knowledge of the applicable standards and directives
- ▶ Knowledge of and compliance with this document and all safety information

1.4 Safety Instructions



WARNING: This chapter contains important safety and operating instructions. Read and keep this manual for future reference.

1. Before using the unit, read all instructions and cautionary marking on the unit, the batteries and all appropriate sections of this manual. The company has the right not to quality assurance, if not according to the instructions of this manual for installation and cause equipment damage.
2. All the operation and connection please professional electrical or mechanical engineer.
3. All the electrical installation must comply with the local electrical safety standards.
4. When install PV modules in the daytime, installer should cover the PV modules by opaque materials, otherwise it will be dangerous as high terminal voltage of modules in the sunshine.
5. **CAUTION**-To reduce risk of injury, charge only deep-cycle lead-acid type rechargeable batteries and lithium batteries. Other types of batteries may burst, causing personal injury and damage.
6. Please be clear which kind of battery system you want, lithium battery system or lead-acid battery system, if you choose the wrong system, energy storage system can't work normally.
7. **NEVER** charge a frozen battery.
8. Be very cautious when working with metal tools on or around batteries. A potential risk exists to drop a tool to spark or short circuit batteries or other electrical parts and could cause an explosion.
9. For optimum operation of this inverter, please follow required spec to select appropriate cable size. It's very important to correctly operate this inverter.
10. Please strictly follow installation procedure when you want to disconnect AC or DC terminals. Please refer to INSTALLATION section of this manual for the details.
11. **GROUNDING INSTRUCTIONS** -This inverter should be connected to a permanent grounded wiring system. Be sure to comply with local requirements and regulation to install this inverter.
12. **NEVER** cause AC output and DC input short circuited. Do NOT connect to the mains when DC input short circuits.
13. Make sure the inverter is completely assembled, before the operation.
14. Do not disassemble the unit. Take it to a qualified service center when service or repair is required. Incorrect re-assembly may result in a risk of electric shock or fire.
15. To reduce risk of electric shock, disconnect all wirings before attempting any maintenance or cleaning. Turning off the unit will not reduce this risk.

2. Product Overview

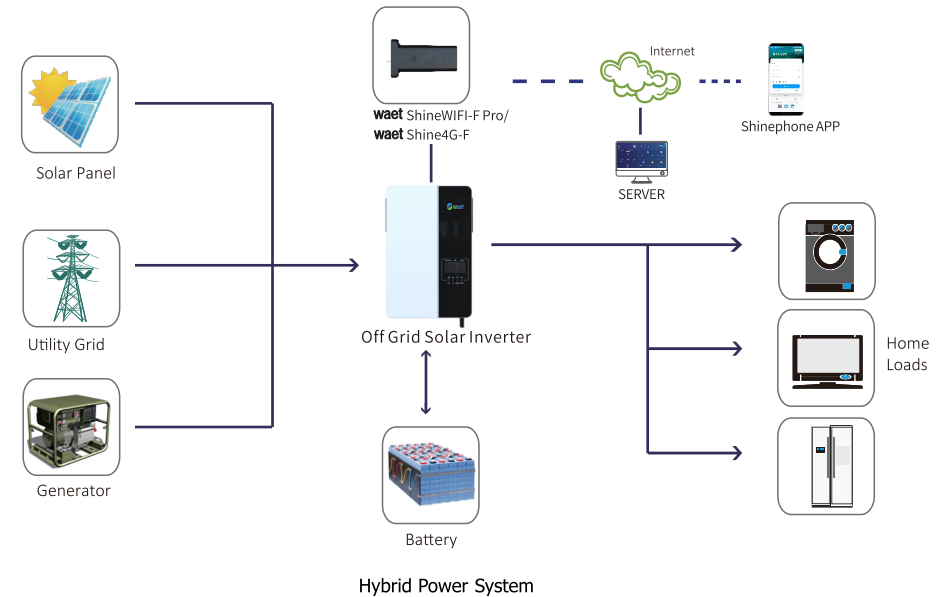

This is a multifunctional off grid solar inverter, integrated with a MPPT solar charge controller, a high frequency pure sine wave inverter and a UPS function module in one machine, which is perfect for off grid backup power and self-consumption applications. This inverter can work with or without batteries. The whole system also need other devices to achieve complete running such as PV modules, generator, or utility grid. Please consult with your system integrator for other possible system architectures depending on your requirements. The WiFi / 4G module is a plug-and-play monitoring device to be installed on the inverter. With this device, users can monitor the status of the PV system from the mobile phone or from the website anytime anywhere.

2.1 Product Features

- ▶ Rated power 3.5KW, power factor 1.
- ▶ 1 strings of MPPT, Max. PV array power 4500watt.
- ▶ MPPT Voltage range 120Vdc-450Vdc, 500Vdc.
- ▶ Built-in ATS for automatic grid and generator switching.
- ▶ Built-in anti-dust kit for harsh environment.
- ▶ MC4 PV input connector.
- ▶ Parallel operation up to 9 unit (only with battery connected).
- ▶ WIFI/ 4G remote monitoring (optional) .
- ▶ Able to work with or without battery.
- ▶ With CAN/RS485 for BMS communication.

2.2 Panel and Port Definitions

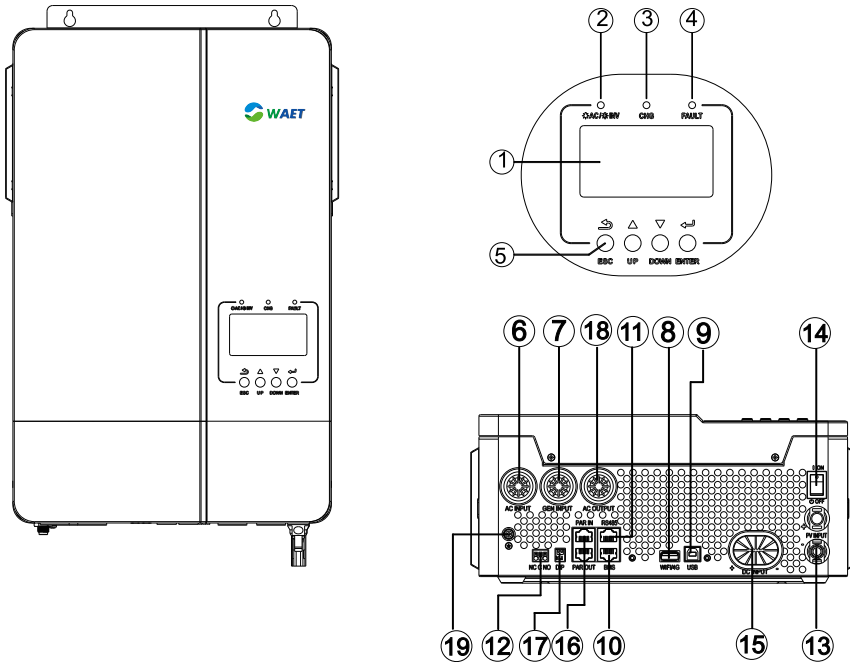

Panel operation	
1. LCD display	2. Status indicator
3. Charging indicator	4. Fault indicator
5. Function buttons	
Connection port	
6. AC input	7. Generator input
13. PV input	15. Battery input
18. AC output	19. GND
Communication port	
8. WIFI/ 4G communication port	9. USB communication port
10. BMS communication port (support CAN/RS485)	11. RS485 communication port (for expansion)
16. Parallel	17. DIP
Other	
12. Dry contact	14. Power on/off switch
20. Circuit breaker	

3. Installation Instructions

3.1 Accessory list

Before installation, please inspect the unit. Be sure that nothing inside the package is damaged. You should have received the following items in the package:

Part List			A	B	C	D	E
Item	Item Name	Qty					
A	The unit	1					
B	Communication cable	1					
C	Parallel communication cable	1					
D	MC4 connector	2					
E	User manual	1					

3.2 Points for attention

Consider the following points before selecting where to install:

Install this inverter at eye level in order to allow the LCD display to be read at all times.

- ▶ The ambient temperature should be between 0°C and 55°C to ensure optimal operation.
- ▶ The recommended installation position is to be adhered to the wall vertically.
- ▶ Do not install in too narrow confined space and pay attention to ventilation.
- ▶ Be sure to keep other objects and surfaces as shown in the right diagram to guarantee sufficient heat dissipation and to have enough space for removing wires.

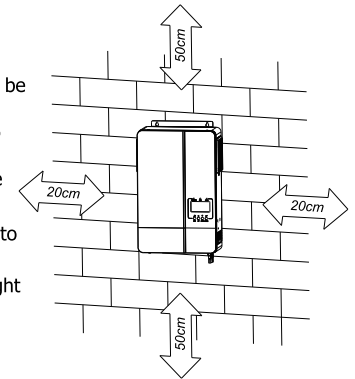

- ⚠ **If the energy storage is installed in areas with salt damage, it will be corroded and may cause fire. Therefore, do not install it outdoors in areas with salt damage. The areas with salt damage are defined as the areas which are not 500m away from shore or will be affected by sea breezes. The areas affected by the sea breezes vary depending on meteorological conditions (e.g. typhoons, monsoons) or topographical conditions (dams, hills).**

- ⚠ **SUITABLE FOR MOUNTING ON CONCRETE OR OTHER NON-COMBUSTIBLE SURFACE ONLY.**

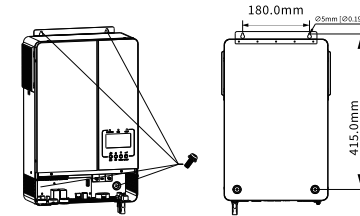

Install the unit by screwing three screws. It's recommended to use M4 or M5 screws.

Preparation for wiring

Before connecting all wiring, please take off bottom cover by removing four screws as shown below.

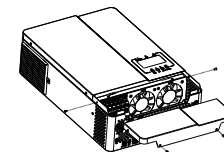

3.3 Battery Connection

⚠ WARNING!

All wiring must be performed by a qualified person.

- Shock Hazard: Installation must be performed with care due to high battery voltage in series.
- Always disconnect all circuit breakers before making connections to the battery power cable.
- Make sure the battery power cable positive (+) must be connected to battery positive (+), negative (-) must be connected to battery negative (-).
- Do not place anything between the flat part of the inverter terminal and the ring terminal. Otherwise, a short circuit may occur, resulting in overheating and fire.
- Do not apply anti-oxidant substance on the terminals before terminals are connected tightly.

3.3.1 Wiring preparation

1. For safety operation and regulation compliance, it's requested to install a separate DC breaker (over-current protector) or disconnect device between battery and inverter. It may not be requested to have a disconnect device in some applications, however, it's still requested to have DC breaker installed. Please refer to typical amperage in below table as required breaker size.

Recommended DC breaker specification of battery for a single inverter:

Model	1 unit*
SPF 3500 ES Lite	100A / 60VDC

2. It's very important for system safety and efficient operation to use appropriate cable for battery connection. To reduce risk of injury, please use the proper recommended cable and terminal size as below.

Recommended battery cable and terminal size:

Model	Wire Size	Torque value
SPF 3500 ES Lite	1 * 4 AWG	22mm ²
		2-3 Nm

O-type terminal:

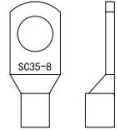

3. **Battery Module Selection:** Choose the appropriate battery according to the actual situation.

Battery Type	Recommended specifications
Lead-acid Battery	100Ah capacity battery
Lithium Battery	100Ah capacity battery

3.3.2 Battery power cable connection

Please follow below steps to implement battery connection:

1. Assemble battery ring terminal based on recommended battery cable and terminal size.
2. Connect all battery packs as units requires.
3. Insert the ring terminal of battery cable flatly into battery connector of inverter and make sure the bolts are tightened with torque of 2Nm. Make sure polarity at both the battery and the inverter/charge is correctly connected and ring terminals are tightly screwed to the battery terminals.

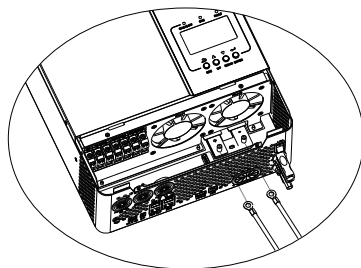

3.3.3 Lithium battery communication cable connection

If used with lithium batteries, make sure to connect the BMS communication cable between the battery and the inverter. It is recommended to use lithium batteries that have been tested with our configuration.

Please follow below steps to implement BMS communication cable connection:

1. Connect one end of the battery's communication cable to the inverter's BMS communication port (below left), which supports RS485 or CAN protocols.

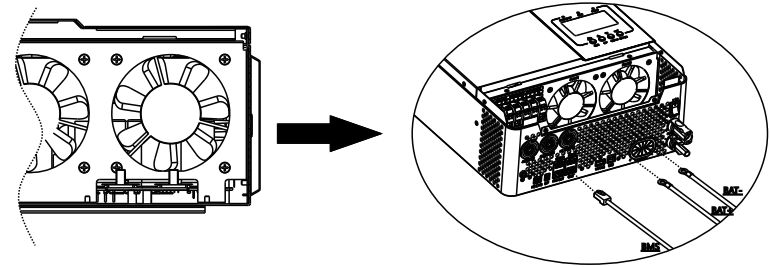

2. The other end of the battery communication cable plugs into the battery communication port (RS485 or CAN).

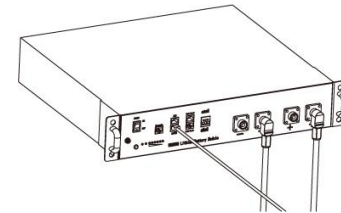

3. The inverter BMS port pin and RS485 port pin assignment shown as below:

Pin number	BMS port	RS485 port (for expansion)
1	RS485B	RS485B
2	RS485A	RS485A
3	--	--
4	CANH	--
5	CANL	--
6	--	--
7	--	--
8	--	--

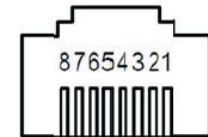

Note: The RS485 port (for expansion) is used for communication expansion and connection to external devices.

Note: In order to ensure the normal communication of lithium battery BMS, please set the battery type as "Li" in program 5, and then LCD will automatically switch to programme 36 to select the communication protocol. You can Choose RS485 communication protocol which is from L01 to L50, and you can also choose CAN Communication protocol which is from L51 to L99. (About the specific protocol address of the inverter, please consult the dealer or manufacturer to choose which communication protocol to match the BMS.)

3.4 AC Connection

⚠ WARNING!

- All wiring must be performed by a qualified personnel.
- Shock Hazard: Be sure that AC power source is disconnected before attempting to wire it to the unit.
- Always disconnect all circuit breakers before making AC input/GEN/AC output connection.
- Be sure to connect AC wires with correct polarity. If L and N wires are connected reversely, it may cause utility short-circuited when these inverters are worked in parallel operation.
- There are three terminal blocks with "AC INPUT", "GEN" and "AC OUTPUT" markings. Please do NOT mis-connect input and output connectors.
- Appliances such as air conditioner are required at least 2~3 minutes to restart because it's required to have enough time to balance refrigerant gas inside of circuits. If a power shortage occurs and recovers in a short time, it will cause damage to your connected appliances. To prevent this kind of damage, please check with manufacturer of air conditioner that if it's equipped with time-delay function before installation. Otherwise, this off grid solar inverter will trig overload fault and cut off output to protect your appliance but sometimes it still causes internal damage to the air conditioner.

3.4.1 Connection preparation

1. Before connecting to AC input power source, please install a **separate** AC breaker between inverter and AC input power source. This will ensure the inverter can be securely disconnected during maintenance and fully protected from over current of AC input. Please refer to typical amperage in below table as required breaker size.

Recommended breaker specification of AC input for a single inverter:

Model	1 unit*
SPF 3500 ES Lite	40A / 230VAC

2. It's very important for system safety and efficient operation to use appropriate cable for AC input connection and GEN connection. To reduce risk of injury, please use the proper recommended cable size as below.

Recommended AC wires size:

Model	Wire Size	Torque value
SPF 3500 ES Lite	1 * 10 AWG	6mm ² 1.2-1.6 Nm

3. When the generator is used as the AC input source of the inverter, the generator power needs to be matched according to the load power. In order to prevent the generator's output voltage, frequency and waveform from being affected due to too large a load, and thus not being able to meet the AC input conditions of the inverter resulting in an AC input cut-out, the following recommendations are made for the generator power.

load	Power Recommendation	
	Inductive load <= 2KW	
generator	Single Phase	>= 10KVA
	Three-phase parallel system	>= 20KVA

3.4.2 AC Input/GEN/Output wires Connection:

Please follow the steps below to make AC output/AC input/GEN connections:

1. Remove the insulation covers of the seven wires.
2. Connect the PE protection line first, and then lock in the AC output line, AC input line, and GEN line in order. Corresponding polarity positions marked on the terminals.

Please refer to the following:

- ⊕ → Ground (yellow-green)
- L → LINE (brown or black)
- N → Neutral (blue)

1. First, insert AC output wires according to polarities indicated on terminal block and tighten terminal screws.

- L → LINE (brown or black)
- N → Neutral (blue)

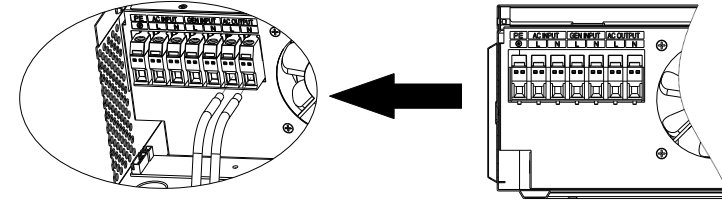

2. Second, insert AC input wires according to polarities indicated on terminal block and tighten terminal screws.

- ⊕ → Ground (yellow-green)
- L → LINE (brown or black)
- N → Neutral (blue)

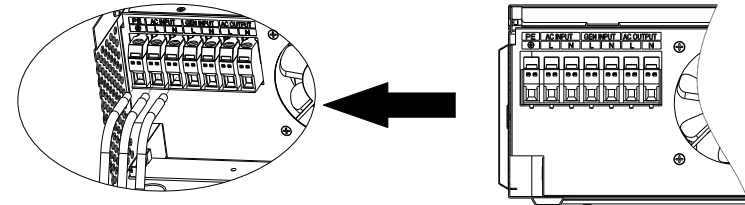

3. Last, insert GEN wires according to polarities indicated on terminal block and tighten the terminal screws.

- L → LINE (brown or black)
- N → Neutral (blue)

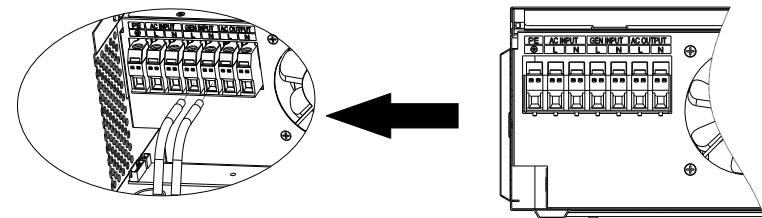

4. Make sure the inverter metal housing is grounded (Ground in the grid system).

- ⊕ → Ground (yellow-green)

R-type terminal:

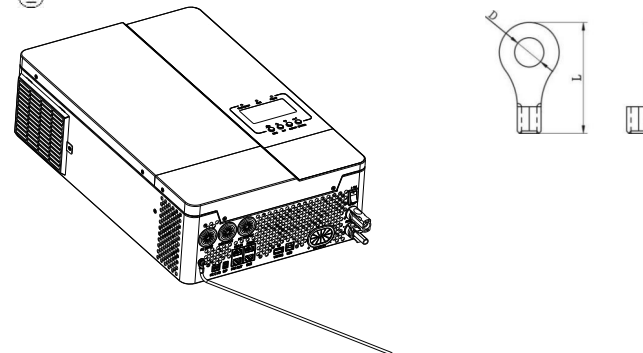

Precautions:

- 1) Before performing the above operations, please ensure that your operating environment is: Non-energized environment.
 - 2) After inserting the wire according to the polarity marked on the terminal, don't forget to check that the screw is tightened.
 - 3) After you complete all wiring, please check again to confirm whether the corresponding wires are connected in the correct position to avoid misoperation that may cause the inverter to fail to work properly or damage your equipment.
- These details that cannot be ignored ensure a good user experience to a certain extent.

3.5 PV Connection

WARNING!

- All wiring must be performed by a qualified personnel.
- Shock Hazard : Operation with power on is strictly prohibited.
- Before connecting the PV input, be sure to turn off all circuit breakers and confirm that the machine is powered off.
- Be sure to connect PV cable with correct polarity.

3.5.1 Connection preparation

1. Before connecting to PV modules, please install **separately** a DC circuit breaker between inverter and PV modules.

Recommended breaker specification of PV input for a single inverter:

Model	1 unit
SPF 3500 ES Lite	25A / 500Vdc

2. It's very important for system safety and efficient operation to use appropriate cable for PV module connection. To reduce risk of injury, please use the proper recommended cable size as below

Model	Wire Size	Torque value
SPF 3500 ES Lite	1 * 12 AWG	4mm ² 1.2-1.6 Nm

3. PV Module Selection:

When selecting proper PV modules, please be sure to consider below parameters:

1. Open circuit Voltage (Voc) of PV modules not exceeds max. PV array open circuit voltage of inverter. Exceeding the limit will cause damage to the inverter.
2. Open circuit Voltage (Voc) of PV modules should be higher than start-up voltage. Lower than will lead to insufficient photovoltaic.

INVERTER MODEL	SPF 3500 ES Lite
Max. PV Array Open Circuit Voltage	500Vdc
Start-up Voltage	150Vdc
PV Array MPPT Voltage Range	120Vdc~450Vdc (Recommend 370 Vdc)
Quantity Of PV Panels	Recommend 3~9 photovoltaic panels

3.5.2 PV cable Connection:

Please follow below steps to implement PV module connection:

1. Remove insulation sleeve 10 mm for positive and negative conductors.

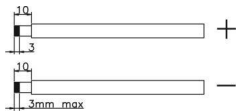

2. Insert PV panel positive and negative cables into MC4 terminal, then connect positive pole(+)of connection cable to positive pole(+)of PV input connector, connect negative pole(-)of connection cable to negative pole(-) of PV input connector.

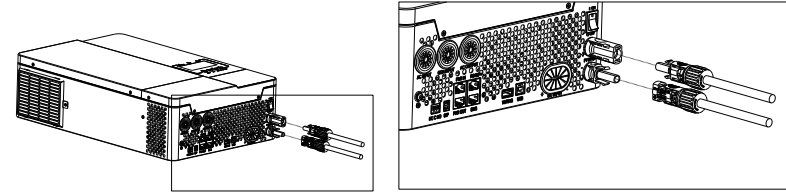

3.6 Communication Connection

Please use supplied communication cable to connect to inverter and PC. Follow on-screen instruction to install the monitoring software. For the detailed software operation, please check user manual of software. The monitoring software is downloadable from our website www.ginverter.com.

3.7 Dry Contact Signal

There is one dry contact(3A/250VAC) available on the rear panel. Dry contacts are used to connect generators. As shown in the table below. When the inverter meets the conditions on the left, it will perform the function on the right. It could be used to deliver signal to external device when battery voltage reaches warning level.

Unit Status	Condition		Dry contact port:		
			NC & C	NO & C	
Power Off	Unit is off and no output is powered		Close	Open	
Power On	Output is powered from Utility	Battery voltage (SOC) < Low DC warning voltage(SOC)	Open	Close	
		Battery voltage(SOC) > Setting value in Program 13 or battery charging reaches floating stage	Close	Open	
	Output is powered from Battery or Solar	Program 01 is set as SBU or Solar first	Battery voltage (SOC) < Setting value in Program 12	Open	Close
		Battery voltage (SOC) > Setting value in Program 13 or battery charging reaches floating stage	Close	Open	

Final Assembly

Double check that all wiring is correct. Please put bottom cover back by screwing four screws as shown below.

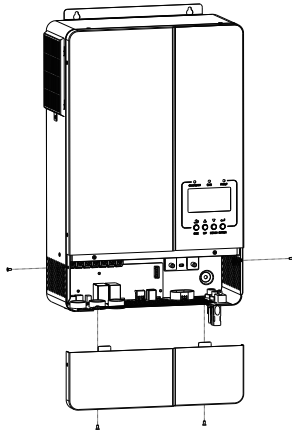

3.8 Wiring system for inverter

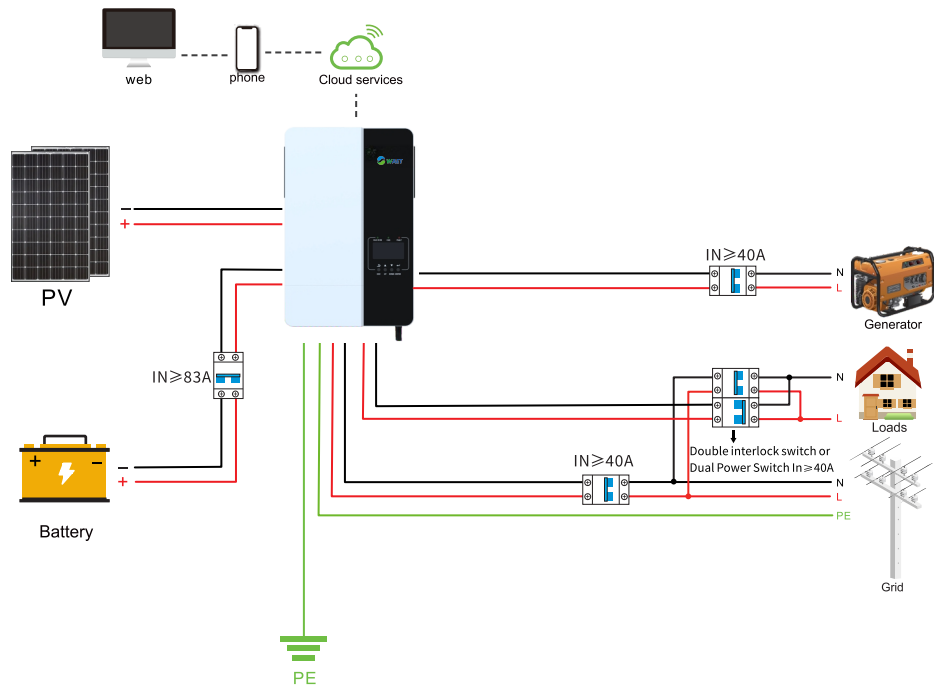

4. Operation

4.1 Power ON/OFF

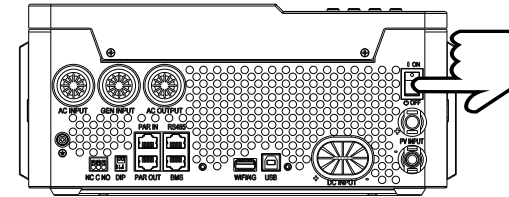

After correct installation, switch on the battery switch, switch on the inverter switch, wait about 30 seconds, inverter output.

4.2 Display Panel Introduction

The operation and display panel, shown in below chart, is on the front panel of the inverter. It includes three indicators, four function keys and a LCD display, indicating the operating status and input/output power information.

1. LCD display
2. Status indicator
3. Charging indicator
4. Fault indicator
5. Function buttons

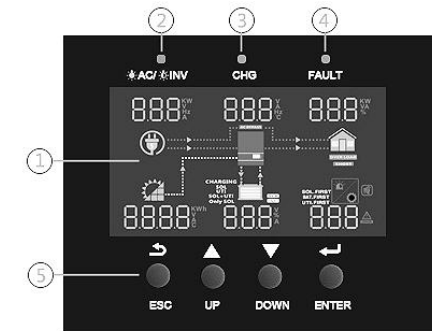

LED Indicator

LED Indicator		Messages	
☀️ AC / ⚡️ INV	Green	Solid On	Output is powered by utility in Line mode.
		Flashing	Output is powered by battery or PV in battery mode.
☀️ CHG	Green	Solid On	Battery is fully charged.
		Flashing	Battery is charging.
⚠️ FAULT	Red	Solid On	Fault occurs in the inverter.
		Flashing	Warning condition occurs in the inverter.

Function Buttons

Button	Description
ESC	To exit setting mode
UP	To go to previous selection
DOWN	To go to next selection
ENTER	To confirm the selection in setting mode or enter setting mode

4.2.1 LCD Display Icons

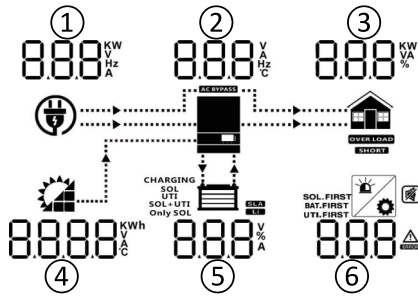

Icon	Description
AC Input Information	
	AC input icon
①	Indicate AC input power, AC input voltage, AC input frequency, AC input current
	Indicate AC power loads in bypass
PV Input Information	
	PV input icon
④	Indicate PV power, PV voltage, PV current, etc
Output Information	
	Inverter icon
②	Indicate output voltage, output current, output frequency, inverter temperature
Load Information	
	Load icon
③	Indicate power of load, power percentage of load
	Indicate overload happened
	Indicate short circuit happened
Battery Information	
	Indicate battery level by 0-24%, 25-49%, 50-74% and 75-100% in battery mode and charging status in line mode.
⑤	Indicate battery voltage, battery percentage, battery current
	Indicate SLA battery
	Indicate lithium battery
	Indicate charging source priority: solar first, solar and utility, or only solar
Other Information	
	Indicate output source priority: solar first, utility first, SBU mode or SUB mode
⑥	Indicate warning code or fault code
	Indicate a warning or a fault is happening
	Indicate it's during setting values
	Indicate the alarm is disabled

In battery charge mode, battery icon will present Battery Charging Status		
Status	Battery voltage	LCD Display
Constant Current mode / Constant Voltage mode	<48V	4 bars will flash in turns.
	48 ~ 50V	Bottom bar will be on and the other three bars will flash in turns.
	50 ~ 52V	Bottom two bars will be on and the other two bars will flash in turns.
	> 52V	Bottom three bars will be on and the top bar will flash.
Floating mode. Batteries are fully charged.		4 bars will be on.

In battery discharge mode, battery icon will present Battery Capacity		
Load Percentage	Battery Voltage	LCD Display
Load >50%	< 41.2V	
	41.2 ~43.2V	
	43.2~45.2V	
	> 45.2V	
50%> Load > 20%	< 43.6V	
	43.6~46V	
	46~47.6V	
	> 47.6V	
Load < 20%	< 44.8V	
	44.8~46.8V	
	46.8~48.8V	
	> 48.8	

4.2.2 Display Information

The LCD display information will be switched in turns by pressing "UP" or "DOWN" key. The selectable information is switched as below order: voltage, frequency, current, power, firmware version.

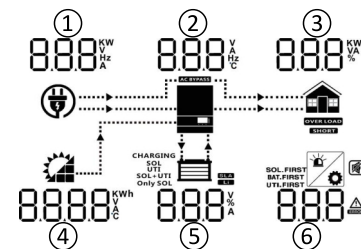







Setting Information	LCD display
① AC Input voltage (If it flashes, it indicates that the input voltage of the generator is displayed at this time, and the current, power and frequency displayed after turning the page are also the input parameters of the generator.) ② Output voltage ③ Load percentage ④ PV input voltage ⑤ Battery voltage ⑥ Warning or Fault code (Default Display Screen)	
① AC Input frequency ② Output frequency ③ Load power in VA ④ PV energy sum in KWH ⑤ Battery percentage ⑥ Warning or Fault code	
① AC Input current ② Output current ③ Load percentage ④ PV input current ⑤ Battery charging current ⑥ Warning or Fault code	
① AC input power in Watts ② Inverter temperature ③ Load power in Watts ④ PV energy sum in KWH ⑤ Battery percentage ⑥ Warning or Fault code	
Firmware version (CPU1: 067-00-A11; CPU2:068-00-A11)	
Time (15:20:10, December 15, 2018)	



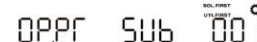

4.2.3 Operating Mode Description

Operation mode	Description	LCD display	
Standby mode / Power saving mode Note: *Standby mode: The inverter is not turned on yet but at this time, the inverter can charge battery without AC output. *Power saving mode: If enabled, the output of inverter will be off when connected load is pretty low or not detected.	No output is supplied by the unit but it still can charge batteries.	Charging by utility and PV energy. 	Charging by utility
		Charging by PV energy 	No charging
Fault mode Note: *Fault mode: Errors are caused by inside circuit error or external reasons such as over temperature, output short circuited and so on.	PV energy and utility can charge batteries.	Charging by utility and PV energy 	Charging by utility
		Charging by PV energy 	No charging
Line Mode	The unit will provide output power from the mains. It can also charge the battery at line mode.	Charging by PV energy 	
		Charging by utility 	
		No battery connected 	
Battery Mode	The unit will provide output power from battery and PV power.	Power from battery and PV energy 	
		Power from battery only 	

4.3 LCD parameter setting

After pressing and holding ENTER button for 3 seconds, the unit will enter setting mode. Press "UP" or "DOWN" button to select setting programs. Then press "ENTER" button to confirm the selection or ESC button to exit.

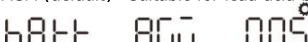
Program	Description	Setting Option
01	Output source priority: To configure load power source priority	Solar first  <p>Solar energy provides power to the loads as first priority. If solar energy is not sufficient to power all connected loads, battery energy will supply power the loads at the same time. Utility provides power to the loads only when any one condition happens:</p> <ul style="list-style-type: none"> - Solar energy is not available - Battery voltage drops to either low-level warning voltage or the setting point in program 12.
		Utility first (default)  <p>Utility will provide power to the loads as first priority. Solar and battery energy will provide power to the loads only when utility power is not available.</p>
		SBU priority  <p>Solar energy provides power to the loads as first priority. If solar energy is not sufficient to power all connected loads, battery will supply power to the loads at the same time. Utility provides power to the loads only when battery voltage drops to either low-level warning voltage or the setting point in program 12.</p>
		SUB priority  <p>Solar energy provides power to the loads as first priority. If solar energy is not sufficient to power all connected loads, solar and utility will power loads at the same time. Battery provides power to the loads only when solar energy is not sufficient and there is no utility.</p>
		Maximum charging current: set total charging current for solar and utility chargers.  <p>(Max. charging current = utility charging current + solar charging current) (If LI is selected in Program 5, this program can't be set up)</p>
		AC input voltage range Appliance (default)  <p>If selected, acceptable AC input voltage range will be within: 90~280VAC</p> <p>UPS  <p>If selected, acceptable AC input voltage range will be within: 170~280VAC</p> </p>

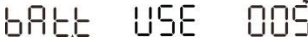
04	Power saving mode enable/disable	Saving mode disable (default)  <p>If disabled, no matter connected load is low or high, the on/off status of inverter output will not be effected.</p>																														
		Saving mode enable  <p>If enabled, the output of inverter will be off when connected load is pretty low or not detected.</p>																														
05	Battery type	AGM (default)—Suitable for lead-acid battery  <table border="1" data-bbox="1515 397 2090 446"> <thead> <tr> <th>Items that cannot be set</th> <th>19</th> <th>20</th> <th>21</th> </tr> </thead> <tbody> <tr> <td>default</td> <td>56.4V</td> <td>54V</td> <td>42V</td> </tr> </tbody> </table> <table border="1" data-bbox="1515 462 2090 600"> <thead> <tr> <th>Items that can be set:</th> <th>default</th> <th>Set range</th> <th>Set requirements</th> </tr> </thead> <tbody> <tr> <td>02</td> <td>60A</td> <td>0A~80A</td> <td></td> </tr> <tr> <td>11</td> <td>30A</td> <td>0A~60A</td> <td></td> </tr> <tr> <td>12</td> <td>46V</td> <td>44~51.2V</td> <td><13 setting value</td> </tr> <tr> <td>13</td> <td>54v</td> <td>48~58.0V</td> <td></td> </tr> </tbody> </table>	Items that cannot be set	19	20	21	default	56.4V	54V	42V	Items that can be set:	default	Set range	Set requirements	02	60A	0A~80A		11	30A	0A~60A		12	46V	44~51.2V	<13 setting value	13	54v	48~58.0V			
		Items that cannot be set	19	20	21																											
		default	56.4V	54V	42V																											
		Items that can be set:	default	Set range	Set requirements																											
		02	60A	0A~80A																												
		11	30A	0A~60A																												
		12	46V	44~51.2V	<13 setting value																											
		13	54v	48~58.0V																												
		Flooded—Suitable for lead-acid battery or flood battery  <table border="1" data-bbox="1515 673 2090 722"> <thead> <tr> <th>Items that cannot be set:</th> <th>19</th> <th>20</th> <th>21</th> </tr> </thead> <tbody> <tr> <td>default</td> <td>58.4V</td> <td>56V</td> <td>43.6V</td> </tr> </tbody> </table> <table border="1" data-bbox="1515 738 2090 876"> <thead> <tr> <th>Items that can be set:</th> <th>default</th> <th>Set range</th> <th>Set requirements</th> </tr> </thead> <tbody> <tr> <td>02</td> <td>60A</td> <td>0A~80A</td> <td></td> </tr> <tr> <td>11</td> <td>30A</td> <td>0A~60A</td> <td></td> </tr> <tr> <td>12</td> <td>48V</td> <td>44~51.2V</td> <td><13 setting value</td> </tr> <tr> <td>13</td> <td>56v</td> <td>48~58.0V</td> <td></td> </tr> </tbody> </table>	Items that cannot be set:	19	20	21	default	58.4V	56V	43.6V	Items that can be set:	default	Set range	Set requirements	02	60A	0A~80A		11	30A	0A~60A		12	48V	44~51.2V	<13 setting value	13	56v	48~58.0V			
		Items that cannot be set:	19	20	21																											
default	58.4V	56V	43.6V																													
Items that can be set:	default	Set range	Set requirements																													
02	60A	0A~80A																														
11	30A	0A~60A																														
12	48V	44~51.2V	<13 setting value																													
13	56v	48~58.0V																														
Lithium (only suitable when communicated with BMS communication)  <table border="1" data-bbox="1515 950 2001 982"> <thead> <tr> <th>Items that cannot be set:</th> <th>02</th> <th>19</th> <th>20</th> </tr> </thead> <tbody> <tr> <td></td> <td></td> <td></td> <td></td> </tr> </tbody> </table> <table border="1" data-bbox="1515 998 2090 1136"> <thead> <tr> <th>Items that can be set:</th> <th>default</th> <th>Set range</th> <th>Set requirements</th> </tr> </thead> <tbody> <tr> <td>11</td> <td>30A</td> <td>0A~60A</td> <td></td> </tr> <tr> <td>12</td> <td>50%</td> <td>10%~95%</td> <td><13 setting value</td> </tr> <tr> <td>13</td> <td>95%</td> <td>15%~100%</td> <td></td> </tr> <tr> <td>21</td> <td>20%</td> <td>5%~50%</td> <td><12 setting value</td> </tr> </tbody> </table>	Items that cannot be set:	02	19	20					Items that can be set:	default	Set range	Set requirements	11	30A	0A~60A		12	50%	10%~95%	<13 setting value	13	95%	15%~100%		21	20%	5%~50%	<12 setting value				
Items that cannot be set:	02	19	20																													
Items that can be set:	default	Set range	Set requirements																													
11	30A	0A~60A																														
12	50%	10%~95%	<13 setting value																													
13	95%	15%~100%																														
21	20%	5%~50%	<12 setting value																													
User-Defined—Suitable for lead-acid battery, battery parameters can be set manually  <table border="1" data-bbox="1515 1234 2090 1437"> <thead> <tr> <th>Items that can be set:</th> <th>default</th> <th>Set range</th> <th>Set requirements</th> </tr> </thead> <tbody> <tr> <td>02</td> <td>60A</td> <td>0A~80A</td> <td></td> </tr> <tr> <td>11</td> <td>30A</td> <td>0A~60A</td> <td></td> </tr> <tr> <td>12</td> <td>46V</td> <td>44~51.2V</td> <td><13 setting value</td> </tr> <tr> <td>13</td> <td>54V</td> <td>48~58.0V</td> <td></td> </tr> <tr> <td>19</td> <td>56.4V</td> <td>48~58.4V</td> <td></td> </tr> <tr> <td>20</td> <td>54V</td> <td>48~58.4V</td> <td></td> </tr> <tr> <td>21</td> <td>42V</td> <td>40~48V</td> <td><12 setting value</td> </tr> </tbody> </table>	Items that can be set:	default	Set range	Set requirements	02	60A	0A~80A		11	30A	0A~60A		12	46V	44~51.2V	<13 setting value	13	54V	48~58.0V		19	56.4V	48~58.4V		20	54V	48~58.4V		21	42V	40~48V	<12 setting value
Items that can be set:	default	Set range	Set requirements																													
02	60A	0A~80A																														
11	30A	0A~60A																														
12	46V	44~51.2V	<13 setting value																													
13	54V	48~58.0V																														
19	56.4V	48~58.4V																														
20	54V	48~58.4V																														
21	42V	40~48V	<12 setting value																													

		User-Defined 2 (suitable when lithium battery without BMS communication or communication protocol not matched with the inverter, battery parameters can be set manually)	
		bAtt US2 005	
		Items that can be set:	default Set range Set requirements
		02	60A 0A~80A
		11	30A 0A~60A
		12	48V 44~51.2V <13 setting value
		13	54V 48~58.0V
		19	54V 48~58.4V
		20	54V 48~58.4V Suggestion=19 setting value
		21	46V 40~48V <12 setting value
06	Auto restart when overload occurs	Restart disable (default) LdFS d1S 006	Restart enable LdFS ENA 006
07	Auto restart when over temperature occurs	Restart disable (default) t1FS d1S 007	Restart enable t1FS ENA 007
08	Output voltage	230V (default) OUtV 230 008	220V OUtV 220 008
		240V OUtV 240 008	208V OUtV 208 008
09	Output frequency	50Hz (default) OUtF 50 009	60Hz OUtF 60 009
10	Number of series batteries connected	bAttN 4 010 (e.g. Showing batteries are connected in 4 series)	
11	Maximum utility & Generator charging current	ACI 30 ^A	
		GENI 30 ^A 011	
		Note: If setting value in Program 02 is smaller than that in Program 11, the inverter will apply charging current from Program 02 for utility charger	
12	Setting voltage point back to utility source when selecting "SBU priority" or "Solar first" in program 01	b2AC 460 ^V 012	

13	Setting voltage point back to battery mode when selecting "SBU priority" or "Solar first" in program 01	AC26 540 ^V 013	
14	Charger source priority: To configure charger source priority	If this off grid solar inverter is working in Line, Standby or Fault mode, charger source can be programmed as below:	
		Solar first CGPF SOL 014	Solar energy will charge battery as first priority. Utility will charge battery only when solar energy is not available.
		Solar and Utility CGPF SOL-UTI 014	Solar energy and utility will both charge battery.
		Only Solar CGPF ONLY SOL 014	Solar energy will be the only charger source no matter utility is available or not.
		If this off grid solar inverter is working in Battery mode or Power saving mode, only solar energy can charge battery. Solar energy will charge battery if it's available and sufficient.	
15	Alarm control	Alarm on (default) BUZZ ON 015	Alarm off BUZZ OFF 015
16	Backlight control	Backlight on (default) LEDb ON 016	Backlight off LEDb OFF 016
17	Beeps while primary source is interrupted	Alarm on (default) ALAr ON 017	Alarm off ALAr OFF 017
18	Overload bypass: When enabled, the unit will transfer to line mode if overload occurs in battery mode.	Bypass disable (default) bYP d1S 018	Bypass enable bYP ENA 018
19	C.V. charging voltage.	CV 56.4 ^V 019	
20	Floating charging voltage.	FLtV 540 ^V 020	
21	Low DC cut-off voltage.	CUtV 420 ^V 021	
		Note: The low voltage alarm point is (program 21) +2V. When this value is reached, the machine reports 04. When reach Low DC cut-off voltage: 1) If battery power is only power source available, inverter will shut down. 2) If PV energy and battery power are available, inverter will charge battery without AC output. 3) If PV energy, battery power and utility are all available, inverter will transfer to line mode and provide output power to loads, and charge the battery at the same time.	

23	AC output mode *This setting is only available when the inverter is in standby mode (Switch off). Note: Parallel operation can only work when battery connected	Single: PRLL SIG 023 ^o	Parallel: PRLL PAL 023 ^o
		L1 Phase: PRLL 3P1 023 ^o	L2 Phase: PRLL 3P2 023 ^o
		L3 Phase: PRLL 3P3 023 ^o	
		When the units are used in parallel with single phase, please select "PAL" in program 23. It requires 3 inverters to support three-phase equipment, 1 inverter in each phase. Please select "3P1" in program 23 for the inverters connected to L1 phase, "3P2" in program 23 for the inverters connected to L2 phase and "3P3" in program 23 for the inverters connected to L3 phase.	
28	Address setting (for expansion)	Addr 1 028 ^o Default 1, 1~255 Settable	
36	RS485 Communication protocol	Protocol 1~50	PtCL L01 036 ^o
	CAN Communication protocol	Protocol 51~99	PtCL L51 036 ^o
37	Real time setting---Year	2018 037 ^o	Default 2018, range 2018~2099
38	Real time setting---Month	12 038 ^o	Default 01, range 01~12
39	Real time setting---Date	13 039 ^o	Default 01, range 01~31
40	Real time setting---Hour	13 040 ^o	Default 00, range 00~23
41	Real time setting---Minute	50 041 ^o	Default 00, range 00~59
42	Real time setting---Second	50 042 ^o	Default 00, range 00~59
49	Utility charging time	0000(default) Allow utility to charge the battery all day run. CHG 017 0000 049 ^o	The time allows utility to charge the battery. Use 4 digits to represent the time period, the upper two digits represent the time when utility start to charge the battery, setting range from 00 to 23, and the lower two digits represent the time when utility end to charge the battery, setting range from 00 to 23. (eg: 2320 represents the time allows utility to charge the battery is from 23:00 to the next day 20:59, and the utility charging is prohibited outside of this period)

50	Utility output time	0000(default) Allow utility to power the load all day run. OUP 017 0000 050 ^o	The time allows utility to power the load. Use 4 digits to represent the time period, the upper two digits represent the time when utility start to power the load, setting range from 00 to 23, and the lower two digits represent the time when utility end to power the load, setting range from 00 to 23. (eg: 2320 represents the time allows utility to power the load is from 23:00 to the next day 20:59, and the utility power is prohibited outside of this period)
55	Setting solar energy supply priority when selecting "SUB priority" in program 01	Charge first (default) SOPd BLU 055 ^o	Solar energy provides power to charge battery as first priority.
		Load first SOPd LBU 055 ^o	Solar energy provides power to the loads as first priority.
65	Generator run time	GEN RUN 017 HOUR 24 065 ^o	Default 24, range 01~24 The time allows Generator to work. Use 2 digits to represent the time period, setting range from 01 to 24.(eg: 02 represents the time allows Generator to run for two hours.
66	BMS Communication Loss	(default) b7SE ENR 066 ^o	If BMS Communication Loss, The inverter 04 and 20 warning Icon flashing , but enable to work for original status without charging.
		b7SE d1S 066 ^o	If BMS Communication Loss, The inverter 04 and 20 warning Icon flashing and disable to work.(cut off the output and can't charge)

5. Parallel Installation Guide

Introduction

This inverter can be used in parallel with two different operation modes.

1. Parallel operation in single phase with up to 9 units.
2. Maximum 9 units work together to support 3-phase equipment. Seven units support one phase maximum.

5.1 Parallel accessories



Parallel communication cable

5.2 Points of Attention for Parallel

- Ensure that all breakers in the line on the load side are disconnected.
- Be sure the length of all battery cables is the same. Otherwise, there will be voltage difference between inverter and battery to cause parallel inverters not working.
- Be sure that all inverters will share the same battery bank. Otherwise, the inverters will transfer to fault mode.
- Each inverter in the parallel system can only be connected to a separate PV string, and it is prohibited for multiple PV ports to share the same string, and there is a risk of blowing up the inverter.
- Recommended battery capacity

Inverter parallel numbers	2	3	4	5	6	7	8	9
Battery Capacity	200AH	300AH	400AH	500AH	600AH	700AH	800AH	900AH

5.3 Wire Connections

5.3.1 Single-phase parallel wire connection

Port	Parallel mode	Charts and descriptions
DC Input left-positive, right-negative		<p>When the inverters are connected in parallel, the + wires are connected together and the - wires are connected together at the DC input . (chart below)</p> <p>In the inverter parallel system, each inverter battery needs to be connected to a DC circuit breaker, single access circuit breaker specifications recommended 100 A. If you choose to access the total circuit breaker at the system end, the recommended access circuit breaker specifications 100 A * the number of parallel (eg: four inverter system access to the total circuit breaker, the recommended access circuit breaker specifications 400)</p>

AC Input	<p>When the inverters are connected in parallel, the N wires are connected together and the L wires are connected together at the AC input. (chart below)</p>
Generator	<p>When the inverters are connected in parallel, the N wires are connected together and the L wires are connected together at the generator input (chart below)</p>
AC Output	<p>When the inverters are connected in parallel, the N wires are connected together and the L wires are connected together at the AC output. (chart below)</p> <p>In an inverter-parallel system, an AC circuit breaker is required to be connected to the load for each inverter, and a single access circuit breaker size of 40A is recommended.</p>
PV Input	<p>Each inverter in the system is individually connected to the PV string (chart below)</p>

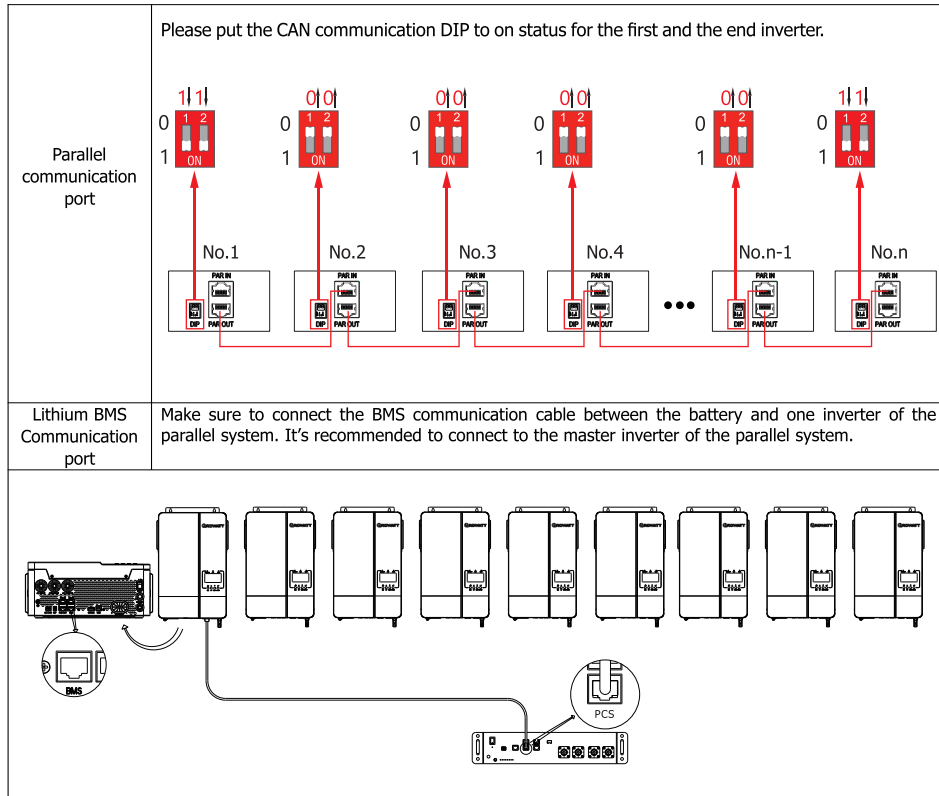

5.3.2 Three-phase parallel wire connection

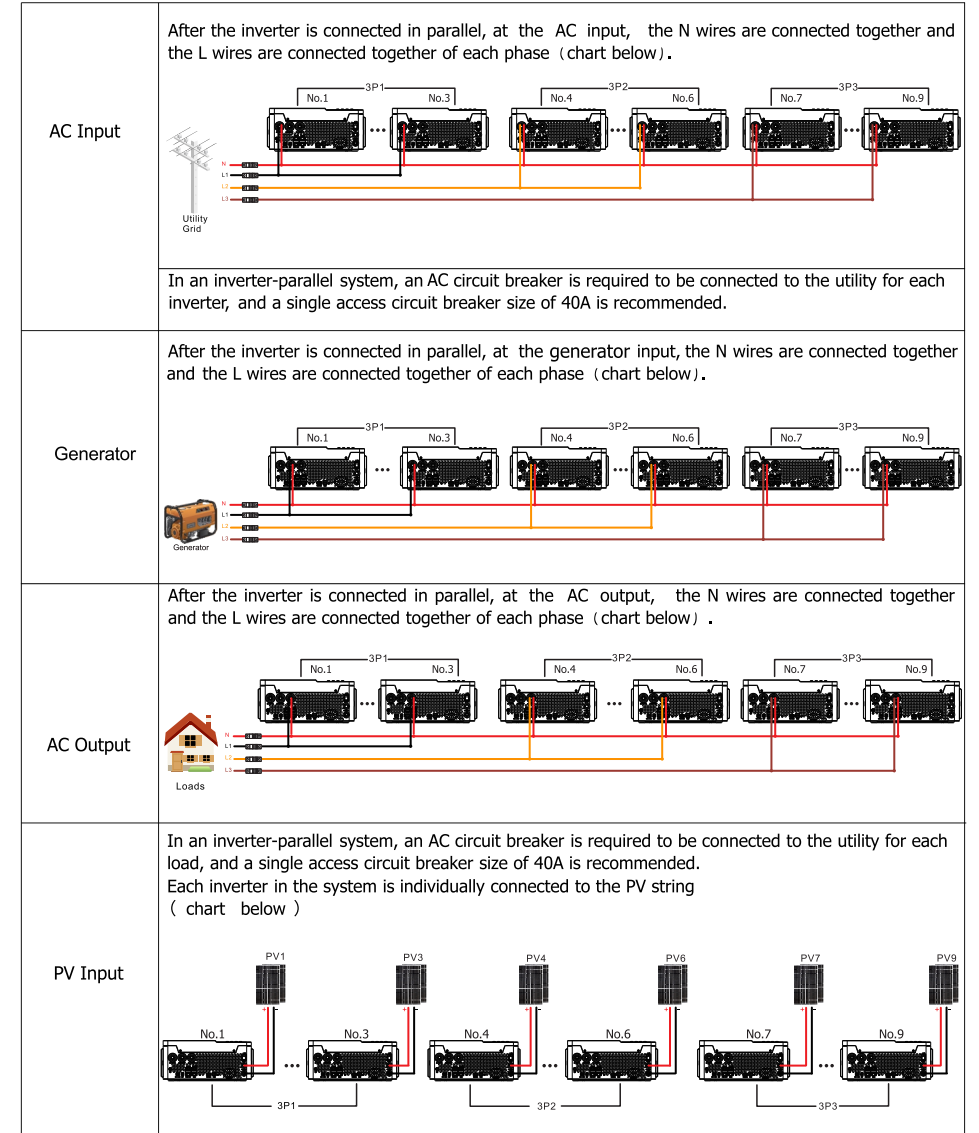
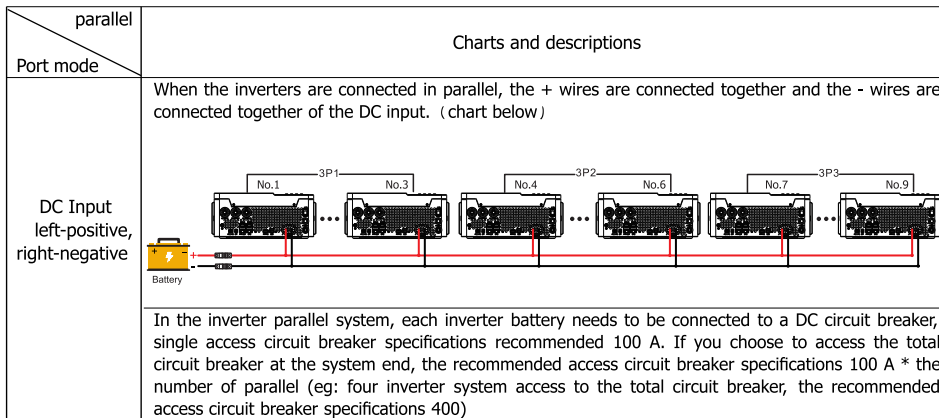

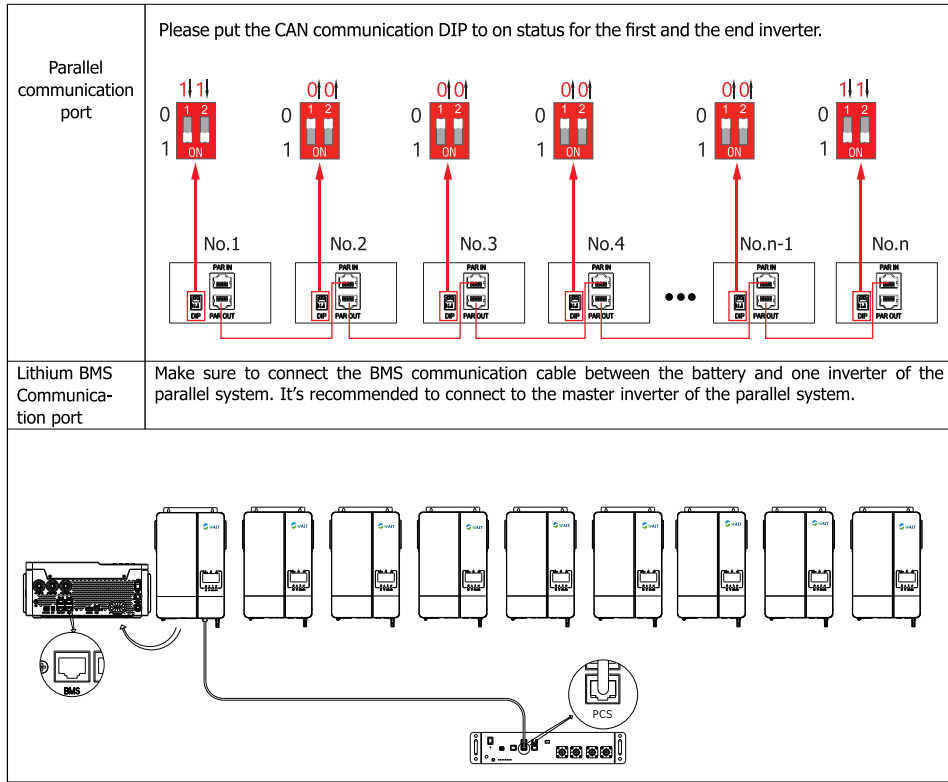

5.4 Parallel Example

Parallel Operation in Single Phase

Single-phase parallel master and slave do not need to be set, the system automatically assigns the master and slave according to the order of start-up, the first one to start is the master, and the rest are the slaves. Be sure to confirm that the wiring is correct, the wiring is shown in the following figure, parallel less than nine wires in order to reduce.

Nine inverters in parallel:

Power Connection

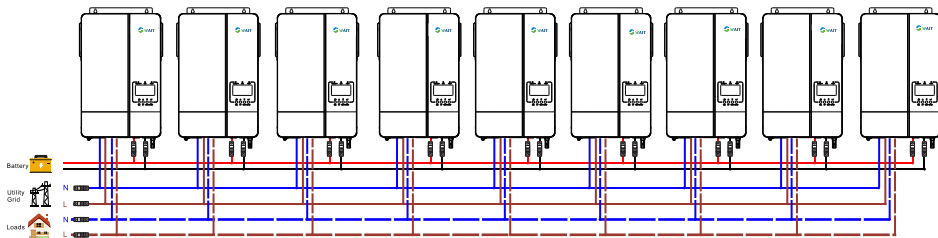

Parallel Operation in Three Phase

Try to connect to the utility at the same time after three-phase parallel connection.

When setting up three-phase parallel, you need to define the master and the slave, see the 5.5 for the specific setting method. Be sure to confirm that the wiring is correct, the wiring method is shown in the table below. The following chart is an example of (3+3+3) (4+3+2)

(3+3+3) Three inverters in one phase, three inverters in second phase and three inverters for the third phase:

Power Connection

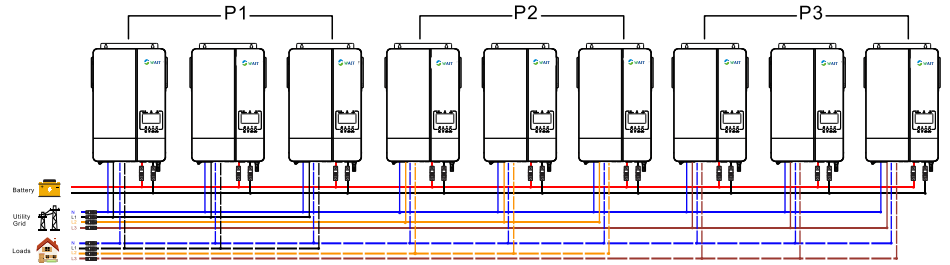

(4+3+2) Four inverters in one phase, three inverters in second phase and two inverters for the third phase:

Power Connection

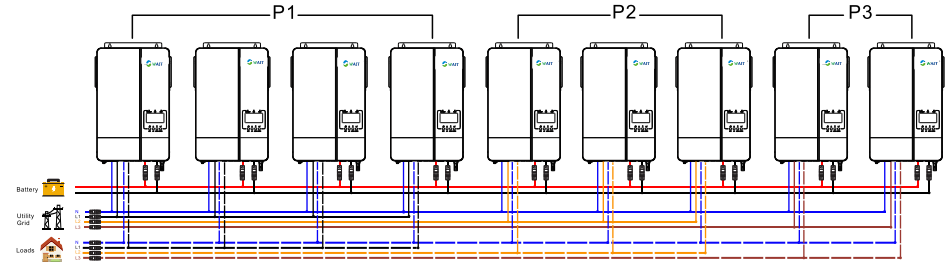

5.5 Parallel setup and display

Refer to Program 23 on Page 21

Parallel in Single Phase

Step 1: Check the following requirements before commissioning:

- Correct wire connection
- Ensure all breakers in Line wires of load side are open and each Neutral wires of each unit are connected together.

Step 2: Turn on each unit and set "PAL" in LCD setting program 23 of each unit. And then shut down all units.

Note: It's necessary to turn off switch when setting LCD program. Otherwise, the setting can not be programmed.

Step 3: Turn on each unit.

LCD display in Master unit	LCD display in Slave unit
0 230 ^v 0.1%	0 230 ^v 0.1%
00 56.4 ^v 45t	00 56.4 ^v 51t

Note: Master and slave units are randomly defined.

Step 4: Switch on all AC breakers of Line wires in AC input. It's better to have all inverters connect to utility at the same time. If not, it will display warning 15.

LCD display in Master unit	LCD display in Slave unit

Step 5: If there is no more fault alarm, the parallel system is completely installed.

Step 6: Please switch on all breakers of Line wires in load side. This system will start to provide power to the load.

Parallel in Three Phase

Step 1: Check the following requirements before commissioning:

- Correct wire connection
- Ensure all breakers in Line wires of load side are open and each Neutral wires of each unit are connected together.

Step 2: Turn on all units and configure LCD program 23 as P1, P2 and P3 sequentially. Then shut down all units.

Note: It's necessary to turn off switch when setting LCD program. Otherwise, the setting can not be programmed.

Step 3: Turn on all units sequentially. Please turn on HOST inverter first, then turn on the rest one by one.

LCD display in L1-phase unit	LCD display in L2-phase unit	LCD display in L3-phase unit

Step 4: Switch on all AC breakers of Line wires in AC input. If AC connection is detected and three phases are matched with unit setting, they will work normally. Otherwise, they will display warning 15/16 and will not work in the line mode.

LCD display in L1-phase unit	LCD display in L2-phase unit	LCD display in L3-phase unit

Step 5: If there is no more fault alarm, the system to support 3-phase equipment is completely installed.

Step 6: Please switch on all breakers of Line wires in load side. This system will start to provide power to the load.

Note 1: If there's only one inverter in L1-phase, the LCD will show as "HST". If there is more than one inverter in L1-phase, the LCD of the HOST inverter will show as "HST", the rest of L1-phase inverters will show as "3P1".

Note 2: To avoid overload occurring, before turning on breakers in load side, it's better to have whole system in operation first.

Note 3: Transfer time for this operation exists. Power interruption may happen to critical devices, which cannot bear transfer time.

5.6 Example of a parallel system diagram

Single-phase parallel wire connection :

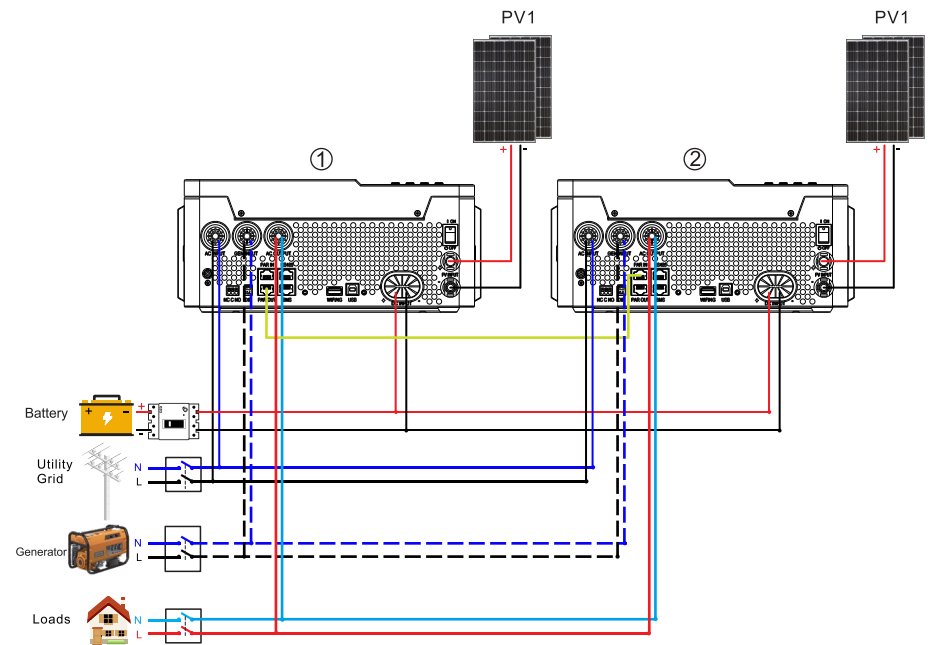

Three-phase parallel wire connection :

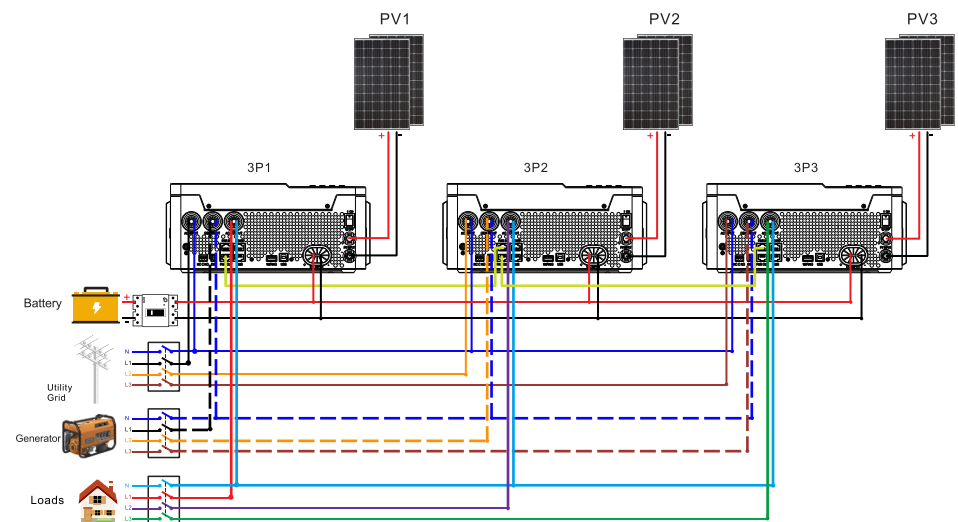

6. Fault Reference Code

6.1 Fault Reference Code

Fault Code	Fault Event	Icon on
01	Fan is locked	01-
02	Over temperature	02-
03	Battery voltage is too high	03-
04	Battery voltage is too low	04-
05	Output short circuited	05-
06	Output voltage is too high.	06-
07	Overload time out	07-
08	Bus voltage is too high	08-
09	Bus soft start failed	09-
11	The main relay failed	11-
51	Over current or surge	51-
52	Bus voltage is too low	52-
53	Inverter soft start failed	53-
55	Over DC voltage in AC output	55-
56	Battery connection is open	56-
57	Current sensor failed	57-
58	Output voltage is too low	58-
60	Negative power fault	60-
61	PV voltage is too high	61-
62	Internal communication error	62-
80	CAN fault	80-
81	Host loss	81-

6.2 Warning Indicator

Warning Code	Warning Event	Audible Alarm	Icon flashing
01	Fan is locked when inverter is on	Beep 3 times every second	01 [△]
02	Over temperature	Beep once every second	02 [△]
03	Battery is over-charged	Beep once every second	03 [△]
04	Low battery	Beep once every second	04 [△]
07	Overload	Beep once every 0.5 second	07 [△]
10	Output power derating	Beep twice every 3 seconds	10 [△]
12	Solar charger stops due to low battery	Beep once every second	12 [△]
13	Solar charger stops due to high PV voltage	Beep once every second	13 [△]
14	Solar charger stops due to overload	Beep once every second	14 [△]
15	Parallel input utility grid different	Beep once every second	15 [△]
16	Parallel input phase error	Beep once every second	16 [△]
17	Parallel output phase loss	Beep once every second	17 [△]
18	Buck over current	Beep once every second	18 [△]
19	Battery disconnect	No beep	19 [△]
20	BMS communication error	Beep once every second	20 [△]
21	PV power insufficient	Beep once every second	21 [△]
22	Parallel forbidden without battery	Beep once every second	22 [△]
25	Parallel inverters' capacity different	Beep once every second	25 [△]
26	PV insulation test failed	Beep once every second	26 [△]
33	BMS communication loss	Beep once every second	33 [△]
34	Cell over voltage	Beep once every second	34 [△]
35	Cell under voltage	Beep once every second	35 [△]
36	Total over voltage	Beep once every second	36 [△]
37	Total under voltage	Beep once every second	37 [△]
38	Discharge over voltage	Beep once every second	38 [△]
39	Charge over voltage	Beep once every second	39 [△]
40	Discharge over temperature	Beep once every second	40 [△]
41	Charge over temperature	Beep once every second	41 [△]
42	Mosfet over temperature	Beep once every second	42 [△]
43	Battery over temperature	Beep once every second	43 [△]
44	Battery under temperature	Beep once every second	44 [△]
45	System shut down	Beep once every second	45 [△]
63	Battery voltage consistent failed	Beep once every second	63 [△]

7. Specifications

7.1 Line Mode Specifications

INVERTER MODEL	SPF 3500 ES Lite
Input Voltage Waveform	Sinusoidal (utility or generator)
Nominal Input Voltage	230Vac
Low Loss Voltage	170Vac±7V (UPS); 90Vac±7V (Appliances)
Low Loss Return Voltage	180Vac±7V (UPS); 100Vac±7V (Appliances)
High Loss Voltage	280Vac±7V
High Loss Return Voltage	270Vac±7V
Max AC Input Voltage	300Vac
Nominal Input Frequency	50Hz / 60Hz (Auto detection)
Low Loss Frequency	40±1Hz
Low Loss Return Frequency	42±1Hz
High Loss Frequency	65±1Hz
High Loss Return Frequency	63±1Hz
Max AC Input Current	40Amp
Efficiency (Line Mode)	>95% (Rated R load, battery full charged)
Transfer Time	10ms typical, 20ms Max@ Single <30ms @ Parallel
Output power derating: When AC input voltage drops to 170V, the output power will be derated.	<p>The graph plots Output Power against Input Voltage. The x-axis has markers at 90V, 170V, and 280V. The y-axis has markers for Rated Power and 20% Power. The power is constant at Rated Power from 170V to 280V, then drops to 20% Power at 90V.</p>

7.2 Inverter Mode Specifications

INVERTER MODEL	SPF 3500 ES Lite
Rated Output Power	3.5KVA/3.5KW
Output Voltage Waveform	Pure Sine Wave
Output Voltage Regulation	230Vac±5%
Output Frequency	50Hz / 60Hz (Auto detection)
Nominal Output Current	15.2A
Max. Output Fault Current/ Duration	80A/ 300µs
Max. Output Over current Protection	58A
Peak Efficiency	93%
Overload Protection	5s@≥150% load; 10s@110%~150% load
Surge Capacity	2* rated power for 5 seconds
Nominal DC Input Voltage	48Vdc
Cold Start Voltage(Lead-Acid Mode)	46.0Vdc
Cold Start SOC(Li Mode)	Default 30%, Low DC Cut-off SOC +10%
Low DC Warning Voltage (Lead-Acid Mode)	44.0Vdc @ load < 20% 42.8Vdc @ 20% ≤ load < 50% 40.4Vdc @ load ≥ 50%
Low DC Warning Return Voltage (Lead-Acid Mode)	46.0Vdc @ load < 20% 44.8Vdc @ 20% ≤ load < 50% 42.4Vdc @ load ≥ 50%
Low DC Cut-off Voltage (Lead-Acid Mode)	42.0Vdc @ load < 20% 40.8Vdc @ 20% ≤ load < 50% 38.4Vdc @ load ≥ 50%
Low DC Cut-off Voltage (Li Mode)	42.0Vdc
Low DC Warning SOC (Li Mode)	Low DC Cut-off SOC +5%
Low DC Warning Return SOC (Li Mode)	Low DC Cut-off SOC +10%
Low DC Cut-off SOC(Li Mode)	Default 20%, 5%~50% settable
High DC Recovery Voltage	56.4Vdc(C.V. charging voltage)
High DC Cut-off Voltage	60.8Vdc
No Load Power Consumption	<60W

7.3 Charge Mode Specifications

Utility Charging Mode		SPF 3500 ES Lite
INVERTER MODEL		SPF 3500 ES Lite
Charging Algorithm		3-Step
Max. AC Charging Current		60Amp (@V _{1/p} =230Vac)
Bulk Charging Voltage	Flooded Battery	58.4Vdc
	AGM / Gel Battery	56.4Vdc
Floating Charging Voltage		54Vdc
Charging Curve		
MPPT Solar Charging Mode		
Max. PV Array Power	4500W (Power derating above 45°C or PV input voltage below 250Vdc)	
Max. PV Input Current	22A	
Start-up Voltage	150Vdc±10Vdc	
PV Array MPPT Voltage Range	120Vdc~450Vdc	
Max. PV Array Open Circuit Voltage	500Vdc	
Max. Inverter Back Feed Current To The Array	0A	
Max. PV Charging Current	80A	
Max. Charging Current (AC Charger Plus Solar Charger)	80A	

7.4 General Specifications

INVERTER MODEL	SPF 3500 ES Lite
Safety Certification	CE
Operating Temperature Range	-10°C to 55°C
Storage temperature	-15°C~ 60°C
Humidity	5% to 95% Relative Humidity (Non-condensing)
Altitude	<2000m
Dimension(D*W*H), mm	435 x 280 x 125
Net Weight, kg	9.2

8. Appendix

Appendix I. Fault information and processing

The energy storage inverter is designed according to the off-grid connected operation standard and meets the safety requirements and electromagnetic compatibility requirements. Before leaving the factory, the inverter undergoes several rigorous tests to ensure that the inverter can operate reliably.



If any of the fault messages listed in Table 6-1 appear on your inverter and the fault has not been removed after restarting, please contact your local dealer or service center. You need to have the following information ready.

1. Inverter serial number;
2. The problem description (including the fault code and indicator status displayed on the LCD, or specific fault video and picture) is as detailed as possible.
3. Basic system component information (such as batteries, photovoltaic panels, load usage and specifications)
4. Your contact information.

In order to give you a clearer understanding of the inverter's fault information, we will list all possible fault codes and their descriptions when the inverter is not working properly

error code	Description	Solutions
F01	Fan is locked	1.Check whether all fans are working properly. 2 Replace the fan.
F02	Internal temperature of component is over 100°C.	Check whether the air flow of the unit is blocked or whether the ambient temperature is too high.
F03	Battery is over-charged.	Restart the unit
	The battery voltage is too high	1.Measure battery voltage in DC input.(Check battery SOC in LCD when use Li battery) 2.Adjust the charging current to less than 0.2C 3.Check if spec and quantity of batteries are meet requirements.
W04	Battery voltage is too low	1.Measure battery voltage in DC input.(Check battery SOC in LCD when use Li battery) 2.Recharge the battery.
F05	Output short circuited	1.Disconnect load and restart the unit 2.Check if wiring is connected well and remove abnormal load.
F07	Overload time out	Reduce the connected load by switching off some equipment.
F08	Bus voltage is too high	1. If you connect to a lithium battery without communication, check whether the voltage points of the program 19 and 21 are too high for the lithium battery. 2. Restart the unit
F09/53/57	Bus soft start failed	Restart the unit
W15	The input status is different in parallel system.	Check if AC input wires of all inverters are connected well.
W16	Input phase is not correct.	Change the input phase S and T wiring.
W17	The output phase not correct in parallel.	1.Make sure the parallel setting are the same system(sigle or paralle; 3P1,3P2,3P3). 2.Make sure all phases inverters are power on.

W19	lead acid battery disconnect	Check if spec and quantity of batteries are meet requirements.
	Lithium battery disconnect	1.Check BMS communication cable connection 2.Check setup parameters
W20	BMS communication error	1. Check whether communication line is correct connection between inverter and battery. 2. Check whether BMS protocol type is correct setting.
F51	Over current or surge	Restart the unit
F52	Bus voltage is too low	
F55	Output voltage is unbalanced	
F61	PV voltage is too high	1. Measure whether the PV voltage in the DC input is consistent with the value displayed on the LCD screen. 2. If consistent, standardize the parallel connection method of PV panels.
F62	Internal communication error	Restart the unit
F80	CAN fault	1. Check whether the parallel communication cables are connected well.
F81	Host loss	2. Check whether Program 23 settings are right for the parallel system.

Other Problem	LCD/LED/Buzzer	Explanation	What to do
Unit shuts down Automatically during startup process.	LCD/LEDs and buzzer will be active for 3 seconds and then complete off.	The battery voltage is too low . (<1.91V/Cell)	1. Re-charge battery. 2. Replace battery.
No response after power on.	No indication.	1.The battery voltage is far too low. (<1.4V/Cell) 2.Battery polarity is connected reversed.	1. Check if batteries and the wiring are connected well. 2. Re-charge battery. 3. Replace battery.
Mains exist but the unit works in battery mode.	Input voltage is 0 on the LCD and green LED is flashing.	Input protector is tripped.	Check if AC breaker is tripped and AC wiring is connected well.
	Green LED is flashing.	Insufficient quality of AC power (Shore or Generator)	1. Check if AC wires are too thin and/or too long. 2. Check if generator (if applied) is working well or if input voltage range setting is correct. (UPS→Appliance)
	Green LED is flashing.	Set "Battery First" or "Solar First" as the priority of output source.	Change output source priority to Utility first.
When it's turned on, internal relay is switching on and off repeatedly.	LCD display and LEDs are flashing	Battery is disconnected.	Check if battery wires are connected well.

Note: To restart the inverter, all power sources need to be disconnected. After the LCD screen light is off, only use the battery to boot.

Appendix II Restore factory settings

After pressing and holding UP and DOWN buttons at the same time for 3 seconds, the unit will enter PASS mode. Change the middle three numbers 000 to 305 Then press "ENTER" button to confirm the selection and Wait about 7 seconds. Press "ESC" to return and the setting is completed.

Program	Setting Option
PASS	PASS 305 000

Appendix III Battery Equalization

43	Battery equalization	Battery equalization enable EQ ENA 043	Battery equalization disable(default) EQ DIS 043
		If "Flooded" or "User-Defined" is selected in program 05, this program can be set up.	
44	Battery equalization voltage	EQ 58.4 044 Default 58.4V, 48.0V~58.4V Settable	
45	Battery equalized time	71 0	Default 60min, 5min~900min Settable
		EQ 60 045	
46	Battery equalized timeout	71 0	Default 120min, 5min~900min Settable
		EQ 120 046	
47	Equalization interval	30 0	Default 30days, 1 days~90 days Settable
		EQ 30 047	
48	Equalization activated immediately	Equalization activated immediately on EQ ON 048	Equalization activated immediately off(default) EQ OFF 048
		If equalization function is enabled in program 43, this program can be setup. If "On" is selected in this program, it's to activate battery equalization immediately and LCD main page will shows "EQ". If "Off" is selected, it will cancel equalization function until next activated equalization time arrives based on program 47 setting. At this time, "EQ" will not be shown in LCD main page.	

Equalization function is added into charge controller. It reverses the buildup of negative chemical effects like stratification, a condition where acid concentration is greater at the bottom of the battery than at the top. Equalization also helps to remove sulfate crystals that might have built up on the plates. If left unchecked, this condition, called sulfation, will reduce the overall capacity of the battery. Therefore, it's recommended to equalize battery periodically.

• How to Apply Equalization Function

You must enable battery equalization function in monitoring LCD setting program 43 first. Then, you may apply this function in device by either one of following methods:

1. Setting equalization interval in program 47.
2. Active equalization immediately in program 48.

• When to Equalize

In float stage, when the setting equalization interval (battery equalization cycle) is arrived, or equalization is active immediately, the controller will start to enter Equalize stage.

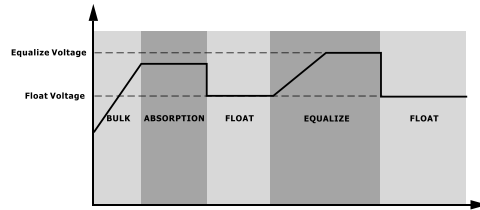

• Equalize charging time and timeout

In Equalize stage, the controller will supply power to charge battery as much as possible until battery voltage raises to battery equalization voltage. Then, constant-voltage regulation is applied to maintain battery voltage at the battery equalization voltage. The battery will remain in the Equalize stage until setting battery equalized time is arrived.

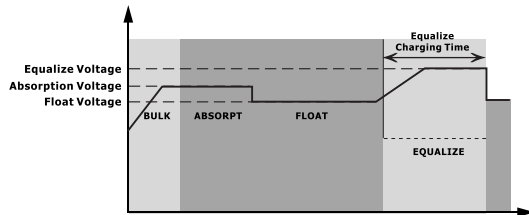

However, in Equalize stage, when battery equalized time is expired and battery voltage doesn't rise to battery equalization voltage point, the charge controller will extend the battery equalized time until battery voltage achieves battery equalization voltage. If battery voltage is still lower than battery equalization voltage when battery equalized timeout setting is over, the charge controller will stop equalization and return to float stage.

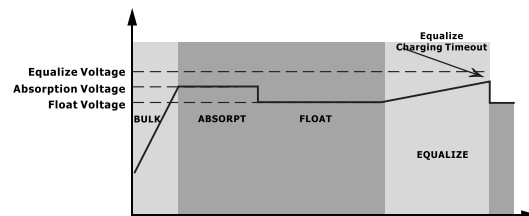

Appendix IV Routine maintenance

To ensure the long-term and good operation of the energy storage system, it is recommended to perform the routine maintenance as described in this section (Cleaning and maintenance of the inverter must be carried out with the power supply disconnected to ensure personal safety).

Items	Methods	Maintenance interval
System cleanliness for inverter	Regularly check the surface of the inverter for dust or other debris and clean it with a dust sponge.	Once every six months to one year
	Regularly check that radiators and vents are not covered with dust and clean them with a soft brush or compressed air.	Once every 3 months.
Electrical connection	Check if any cable connection is off or loose.	Half a year after first debugging and testing, and once every six months to one year thereafter.
	Check if any cable is damaged, and especially if there are cuts on the sheath where the cable contacts with the metal surface.	
Grounding reliability	Check the internal circuit boards and components of the inverter for abnormalities, such as damage, discoloration, etc., and repair and replace them in a timely manner.	Half a year after first debugging and testing, and once every six months to one year thereafter.
	Check if the grounding cable is grounded reliably.	
normal operation	Periodically check the input voltage .output voltage and current of the inverter to ensure that it is operating within its rated range.	Half a year after first debugging and testing, and once every six months to one year thereafter.
	Regularly check the operating status and performance parameters of the inverter via the inverter's monitoring system or display.	
Other Maintenance	Ensure that the inverter is installed in a dry, well-ventilated environment, protected from humidity, heat or excessive dust.	Half a year after first debugging and testing, and once every six months to one year thereafter.

Appendix V WIFI Monitoring

Plug cube WIFI into the WIFI/4G port.

Scan the QR code below to download ShinePhone, also you can search ShinePhone in iOS or Google Play Store, download and install it.
 Note: 1. Make sure you download the latest version.
 2. For further information please visit server. waet.com

